

DeltaSol® AL EHE

RESOL®

beginning with version 2.00

**Solar controller for standard solar systems
with electric backup heating**

Manual for the
specialised craftsman

Installation

Operation

Functions and options

Troubleshooting



11210343



The Internet portal for easy and secure access
to your system data – www.vbus.net

Thank you for buying this RESOL product.
Please read this manual carefully to get the best performance from this unit.
Please keep this manual safe.

en

Manual

www.resol.com

Safety advice

Please pay attention to the following safety advice in order to avoid danger and damage to people and property.

Instructions

Attention must be paid to the valid local standards, regulations and directives!

Information about the product

Proper usage

The solar controller is designed for use in standard solar thermal systems with electric backup heating (electric immersion heater) in compliance with the technical data specified in this manual.

Improper use excludes all liability claims.

CE-Declaration of conformity

The product complies with the relevant directives and is therefore labelled with the CE mark. The Declaration of Conformity is available upon request, please contact the manufacturer.



Note

Strong electromagnetic fields can impair the function of the controller.

- Make sure the controller as well as the system are not exposed to strong electromagnetic fields.

Subject to technical change. Errors excepted.

Target group

These instructions are exclusively addressed to authorised skilled personnel.

Only qualified electricians should carry out electrical works.

Initial installation must be effected by the system owner or qualified personnel named by the system owner.

Description of symbols

WARNING! Warnings are indicated with a warning triangle!



→ **They contain information on how to avoid the danger described.**

Signal words describe the danger that may occur, when it is not avoided.

- **WARNING** means that injury, possibly life-threatening injury, can occur.
- **ATTENTION** means that damage to the appliance can occur.



Note

Notes are indicated with an information symbol.

- Arrows indicate instruction steps that should be carried out.

Disposal

- Dispose of the packaging in an environmentally sound manner.
- At the end of its working life, the product must not be disposed of as urban waste. Old appliances must be disposed of by an authorised body in an environmentally sound manner. Upon request we will take back your old appliances bought from us and guarantee an environmentally sound disposal of the devices.



Solar controller for standard solar systems with electric backup heating

The *DeltaSol*® AL E HE controller is especially designed for standard solar systems with a high-efficiency pump and an electric backup heating.

It is equipped with a PWM output and two high-current relays to which an electric immersion heater of up to 3 kW (230 V~) can be connected. The heater can be directly connected to the controller without the need of auxiliary relays.

For data communication, the controller has a RESOLVBus®.

Contents

1	Overview	4	4	Commissioning	13
2	Installation	5	5	Control parameters and display channels	15
2.1	Mounting	5	5.1	Channel overview	15
2.2	Electrical connection	6	6	Channel overview	17
2.3	Grundfos Direct Sensor™	7	6.1	Display channels	17
2.4	PWM interface	7	6.2	Adjustment channels	20
2.5	Data communication / Bus	7	7	RCTT Remote control (accessory)	33
2.6	Terminal allocation with cable link	8	8	Troubleshooting	34
2.7	Terminal allocation without cable link	9	9	Accessories	37
3	Operation and function	10	9.1	Sensors	38
3.1	Buttons	10	9.2	VBus® accessories	38
3.2	System-Monitoring-Display	10	10	Index	39
3.3	Slide switch	12			
3.4	Flashing codes	12			
3.5	Shortcuts for backup heating off, rapid heat-up and holiday mode	12			

1 Overview

- Direct connection of an electric immersion heater up to 3 kW (230 V~)
- DHW heating with rapid heat-up and thermal disinfection
- Time and temperature control of the electric backup heating
- Solar backup heating suppression
- Heat quantity measurement via VFD Grundfos Direct Sensor™
- PWM output for the speed control of a high-efficiency pump
- Quick access to the holiday and the manual modes
- Status display for a bidirectional HE pump
- Drainback option and tube collector function
- Commissioning menu

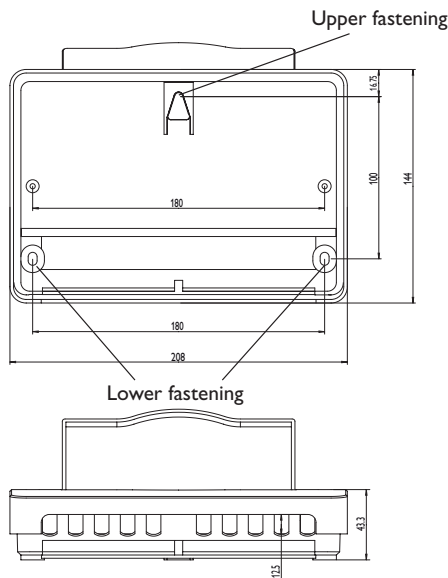

Technical data

Inputs: for 4 Pt1000 temperature sensors, thereof 1 x RCTT, 1 x Grundfos Direct Sensor™ VFD, 1 x PWM feedback

Outputs: 1 semiconductor relay, 2 high-current relays for electric immersion heater, 1 PWM output

PWM frequency: 512 Hz

PWM voltage: 10 V

Switching capacity:

1 (1) A 240 V~ (semiconductor relay)

14 (3) A 240 V~/24 V== (potential-free high-current relay)

Power supply: 100 ... 240 V~ (50 ... 60 Hz)

Supply connection: type Y attachment

Standby: 0.67 W

Temperature controls class: I

Energy efficiency contribution: 1 %

Mode of operation: type 1.B.Y action

Rated impulse voltage: 2.5 kV

Data interface: RESOL VBus®

VBus® current supply: 35 mA

Functions: function control, operating hours counter, tube collector function, heat quantity measurement, time-controlled thermostat function, DHW heating with rapid heat-up, thermal disinfection, holiday mode and backup heating suppression

Housing: plastic, PC-ABS and PMMA

Mounting: wall mounting, mounting into patch panels is possible

Indication / Display: System-Monitoring-Display for visualisation, 16-segment display, 7-segment display, 8 symbols for system states, background illumination and operating control LED

Operation: 3 push buttons and 1 slide switch

Ingress protection: IP 20 / EN 60529

Protection class: I

Ambient temperature: 0 ... 40 °C [32 ... 104 °F]

Pollution degree: 2

Dimensions: 144 x 208 x 43 mm

2 Installation

2.1 Mounting

WARNING! Electric shock!



Upon opening the housing, live parts are exposed!

→ **Always disconnect the device from power supply before opening the housing!**



Note

Strong electromagnetic fields can impair the function of the device.

→ Make sure the device as well as the system are not exposed to strong electromagnetic fields.

The unit must only be located in dry interior rooms.

The controller must additionally be supplied from a double pole switch with contact gap of at least 3 mm.

Please pay attention to separate routing of sensor cables and mains cables.

- Unscrew the crosshead screw from the cover and remove the cover.
- Mark the upper fastening point on the wall. Drill and fasten the enclosed wall plug and screw leaving the head protruding.
- Hang the housing from the upper fastening point and mark the lower fastening points (centres 180 mm).
- Drill and insert the lower wall plug.
- Fasten the housing to the wall with the lower fastening screw and tighten.
- Carry out the electrical wiring in accordance with the terminal allocation (see page 6).
- Put the cover on the housing.
- Attach with the fastening screws.

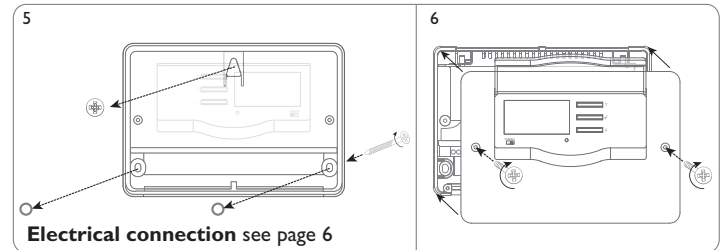
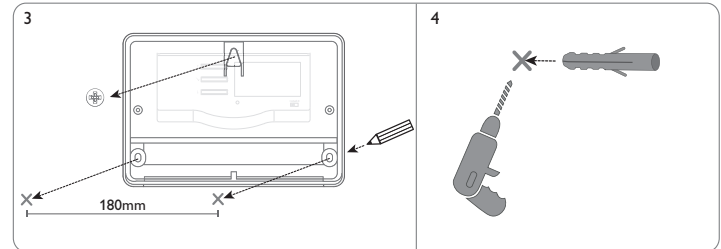
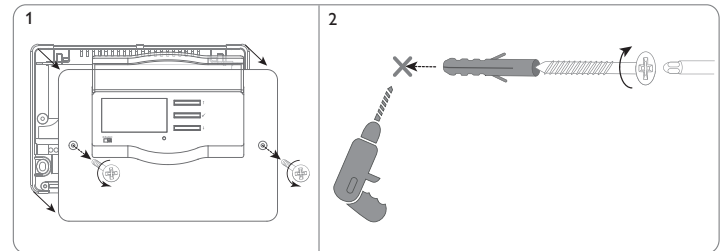

Electrical connection see page 6

2.2 Electrical connection

WARNING! Electric shock!



Upon opening the housing, live parts are exposed!

→ **Always disconnect the device from power supply before opening the housing!**

ATTENTION! ESD damage!



Electrostatic discharge can lead to damage to electronic components!

→ **Take care to discharge properly before touching the inside of the device! To do so, touch a grounded surface such as a radiator or tap!**



Note

Connecting the device to the power supply must always be the last step of the installation!



Note

It must be possible to disconnect the device from the mains at any time.

- Install the mains plug such that it is accessible at any time.
- If this is not possible, install a switch that can be accessed.

Do not use the device if it is visibly damaged!

Attach flexible cables to the housing with the enclosed strain relief and the corresponding screws.

The controller is supplied with power via a mains cable. The power supply of the device must be 100...240 V~ (50...60 Hz).

The controller is equipped with 1 **semiconductor relay** to which a load such as a pump, a valve, etc. can be connected:

- 17 Protective conductor ⊕
- 18 Neutral conductor N
- 19 Conductor R1

The controller is equipped with 2 high-current relays for connecting an **electric immersion heater** of up to 3 kW:

- 16 Protective conductor ⊕
- 23 Mains conductor
- 22 Conductor electric immersion heater
- 21 Neutral conductor mains
- 20 Neutral conductor electric immersion heater

Depending on the product version, mains cables and sensor cables are already connected to the device. If that is not the case, please proceed as follows:

Connect the **temperature sensors** (S1 to S5) to the corresponding terminals with either polarity:

- 1/2 Sensor 1 (collector sensor)
- 3/4 Sensor 2 (store sensor base)
- 5/6 Sensor 3 (store sensor top)
- 7/8 Sensor 4 (return sensor)

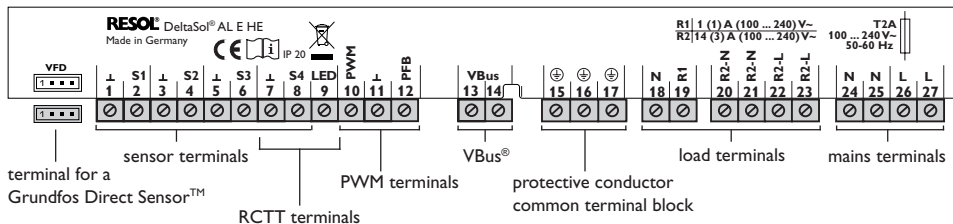

Connect the **RCTT Remote control** (accessory) to the following terminals:

- | | | |
|---|---------------------------------------|-------|
| 7 | GND RCTT Remote control | _____ |
| 8 | Switching input RCTT Remote control | _____ |
| 9 | Signal LED output RCTT Remote control | _____ |

Connect the **RESOL VBus®** to the terminals marked **VBus** with either polarity:

- | | | |
|----|---------------|-------|
| 13 | VBus terminal | _____ |
| 14 | VBus terminal | _____ |

The **mains connection** is at the following terminals:

- | | | |
|----|-------------------------------|-------|
| 25 | Neutral conductor N | _____ |
| 27 | Conductor L | _____ |
| 15 | Protective conductor \oplus | _____ |

The controller comes with the following **cable links** pre-connected:

- | | | |
|----|--|-------|
| 24 | Link from the neutral conductor to terminal 21 | _____ |
| 26 | Link from the conductor L to terminal 23 | _____ |

2.3 Grundfos Direct Sensor™

The controller is equipped with 1 input for a digital VFD Grundfos Direct Sensor™ for measuring the flow rate and the temperature. Connection is made at the VFD terminal (bottom left).

2.4 PWM interface

Speed control of a HE pump is possible via a PWM signal. The pump has to be connected to the relay as well as to the PWM output of the controller. Power is supplied to the HE pump by switching the corresponding relay on or off.

The terminal marked **PFB** is an interface for a bidirectional HE pump.

- | | | |
|----|----------------------------|-------|
| 10 | PWM output, control signal | _____ |
| 11 | PWM, GND | _____ |
| 12 | PWM input, feedback signal | _____ |

2.5 Data communication/Bus

The controller is equipped with the RESOL VBus® for data transfer and energy supply to external modules. The connection is to be carried out at the terminals marked **VBus** (any polarity). One or more RESOL VBus® modules can be connected via this data bus, such as:

- RESOL SD3 smart Display / GA3 Large Display
- RESOL DL2 / DL3 Datalogger
- RESOL KM1 Communication modules

Furthermore, the controller can be connected to a PC or integrated into a network via the RESOL VBus®/USB or VBus® /LAN interface adapter (not included). Different solutions for visualisation and remote parameterisation are available on the RESOL website www.resol.com. On the website, firmware updates are also available.



Note

More accessories on page 37.

2.6 Terminal allocation with cable link

The controller calculates the temperature difference between collector sensor S1 and store sensor S2. If the difference is larger than or identical to the adjusted switch-on temperature difference (DT O), the solar pump will be activated by relay1, and the store will be loaded until the switch-off temperature difference (DT F) or the maximum store temperature (S MX) is reached.

Sensor S3 is used for a thermostat function, which operates relay 2 for backup heating purposes, when the adjusted thermostat switch-on temperature (BH O) is reached. This function can optionally be combined with up to 3 adjustable time frames.

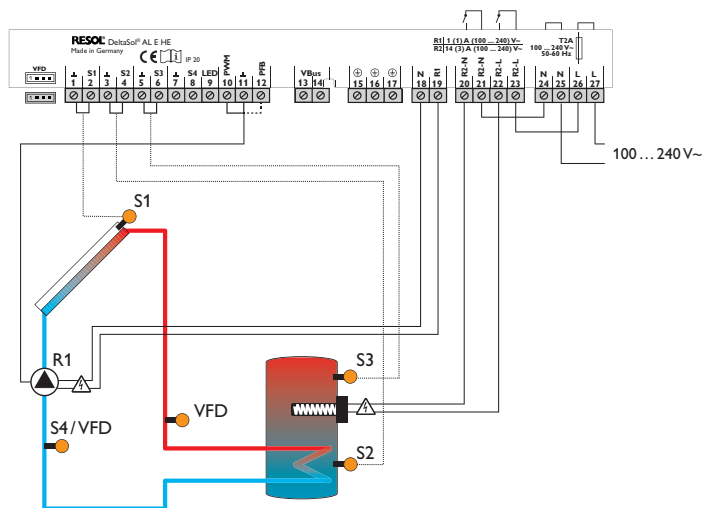

Sensor S3 can optionally be used as the reference sensor for the thermal disinfection function (OTD) or the store emergency shutdown option (OSEM).

Sensor S4 can optionally be connected. For heat quantity measurement, S1 and S2, S1 and VFD or VFD and S4 respectively can be used as flow and return sensors.

WARNING! Electric shock!



Upon opening the housing, live parts are exposed!

→ Always disconnect the device from power supply before opening the housing!



Note:

With this connection type, the immersion heater is supplied with power directly from the mains connection.

Symbol	Description
S1	Collector sensor
S2	Store sensor base
S3	Store sensor top
R1	Solar pump
R2-L	Mains conductor
R2-L	Conductor electric immersion heater
R2-N	Neutral conductor mains
R2-N	Neutral conductor electric immersion heater
⊕	Protective conductor
L/N	Mains terminals

2.7 Terminal allocation without cable link

The controller calculates the temperature difference between collector sensor S1 and store sensor S2. If the difference is larger than or identical to the adjusted switch-on temperature difference (DT O), the solar pump will be activated by relay 1, and the store will be loaded until the switch-off temperature difference (DT F) or the maximum store temperature (S MX) is reached.

Sensor S3 is used for a thermostat function, which operates relay 2 for backup heating purposes, when the adjusted thermostat switch-on temperature (BH O) is reached. This function can optionally be combined with up to 3 adjustable time frames.

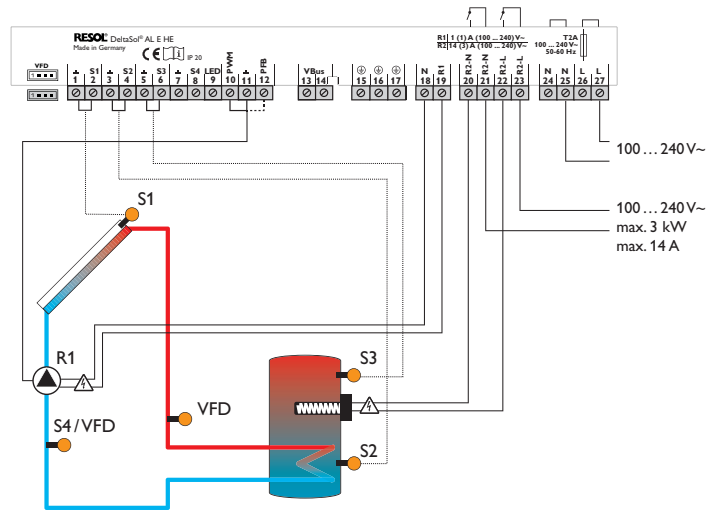

Sensor S3 can optionally be used as the reference sensor for the thermal disinfection function (OTD) or the store emergency shutdown option (OSEM).

Sensor S4 can optionally be connected. For heat quantity measurement, S1 and S2, S1 and VFD or VFD and S4 respectively can be used as flow and return sensors.

WARNING! Electric shock!
 Upon opening the housing, live parts are exposed!
 → **Always disconnect the device from power supply before opening the housing!**

Note:
 With this connection type, the immersion heater is supplied with power indirectly via the mains connection.



→ Remove the pre-connected cable links.



Symbol	Description
S1	Collector sensor
S2	Store sensor base
S3	Store sensor top
R1	Solar pump
R2-L	Mains conductor
R2-L	Conductor electric immersion heater
R2-N	Neutral conductor mains
R2-N	Neutral conductor electric immersion heater
⊕	Protective conductor
L/N	Mains terminals

3 Operation and function

3.1 Buttons

The controller is operated via the 3 buttons next to the display:

Button  : Activating the rapid heat-up function (press and hold down button for 3 s)
Button  : Scrolling upwards, increasing adjustment values (press button briefly)



Button  : Activating the holiday mode (press and hold down button for 3 s)
Button  : **SET** Confirming/selecting (press button briefly)

Button  : Scrolling downwards, reducing adjustment values

During normal operation, display channels will be displayed.

→ In order to scroll between display channels, press buttons  and .

Access to adjustment channels

→ Use button  in order to scroll to the last display channel, then press and hold down button  for approx. 3 s.

If an adjustment channel is shown on the screen, **SET** will be displayed on the right-hand side next to the channel name.

→ Press button  in order to select an adjustment channel.

SET starts flashing.

→ Adjust the desired value with buttons  and .

→ Briefly press button .

SET permanently appears, the adjusted value has been saved.

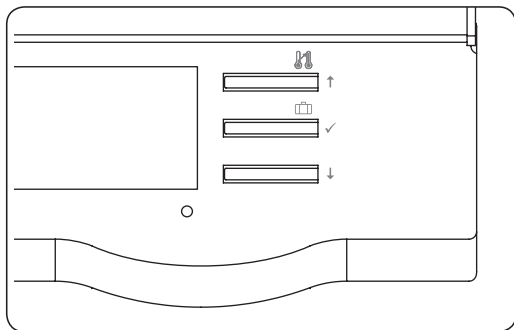

3.2 System-Monitoring-Display

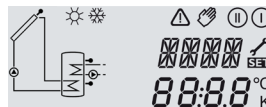

The System-Monitoring-Display consists of 3 blocks: **channel display**, **tool bar** and **system screen**.

3.2.1 Channel display

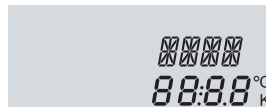

The **channel display** consists of 2 lines. The upper display line is an alphanumeric 16-segment display. In this line, mainly channel names and menu items are displayed. In the lower 7-segment display, values and parameters are displayed.

3.2.2 Tool bar



The additional symbols in the tool bar indicate the current system state.

Permanently shown	Flashing	Status indications:
ⓘ		Relay 1 active
ⓘ		Relay 2 active
☀		Maximum store temperature exceeded
	⚠ + ☀	Store emergency shutdown active
	⚠	Collector emergency shutdown active
ⓘ	☀	Collector cooling active
ⓘ	☀	System cooling active
ⓘ + ☀		Store cooling active
ⓘ + ☀	⚠	Holiday cooling active
	☀	Collector minimum limitation active
☀		Antifreeze function activated
ⓘ	☀	Antifreeze function active
👋 + ⓘ	⚠	Manual mode relay 1 ON
👋 + ⓘ	⚠	Manual mode relay 2 ON
👋	⚠	Manual mode relay 1/2 OFF
🔧	⚠	Sensor fault
🔧 + ⚠		PWM feedback error message
3x 👋		Rapid heat-up not possible, because switch-off temperature exceeded

3.2.3 System screen

The system scheme is indicated on the System-Monitoring-Display. It consists of several system component symbols which are – depending on the current status of the system – either flashing or permanently shown.

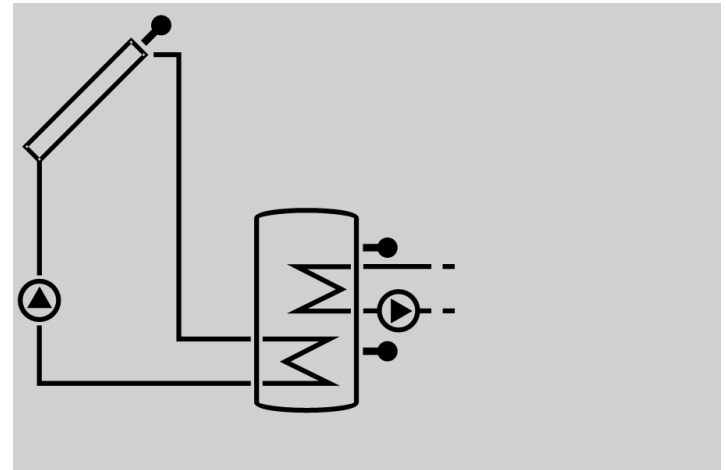

 **Collector**
with collector sensor

 **Temperature sensor**

 **Pump**

 **Store**
with heat exchanger

 **Electric backup heating**
(electric immersion heater)

3.3 Slide switch

By means of the slide switch, the controller can be set to different operating modes:

- Backup heating off = ☼ (left)
- Manual mode = 🖱️ (right)
- Automatic = ⌚ (centre)

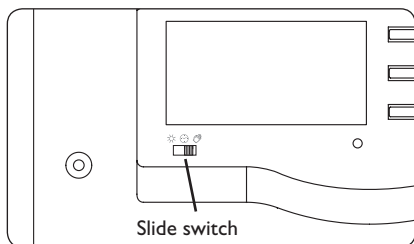

3.4 Flashing codes

3.4.1 System screen

- Pump symbols are flashing when the corresponding relay is on.
- Sensor symbols are flashing if the corresponding sensor display channel is selected.
- Sensors symbols are flashing quickly in the case of a sensor fault.

3.4.2 Operating control LED

- Green: everything OK
- Green flashing: holiday mode / rapid heat-up active
- Red/green flashing: initialisation / manual mode
- Red flashing: sensor fault (sensor symbol is flashing quickly)

3.5 Shortcuts for backup heating off, rapid heat-up and holiday mode

Slide switch position left ☼

Backup heating off

There will be no backup heating or thermal disinfection. The upper heat exchanger in the System-Monitoring-Display will not be indicated, S3 will not be needed.

Slide switch position right 🖱️

Manual mode

Manual mode with a shortcut to the **MAN1/2** parameters.

Button 🕒 (3 s)

Rapid heat-up

When button 🕒 is pressed for 3s, rapid heat-up will become active for the time adjusted in BOOS. The time will be indicated running backwards.

Button 📅 (3 s)

Holiday mode

If button 📅 is pressed and held down for approx. 3s, the adjustment channel **DAYS** appears, allowing to enter the number of days for an absence. If the parameter is set to a value higher than 0, the holiday mode becomes active using the adjustments that have previously been made in the holiday cooling menu. The days will be counted backwards at 00:00. If the value is set to 0, the holiday mode is deactivated.

4 Commissioning

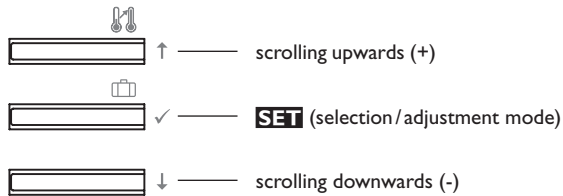

➔ Connect the device to the mains.

The controller runs an initialisation phase.

When the controller is commissioned or when it is reset, it will run a commissioning menu. The commissioning menu leads the user through the most important adjustment channels needed for operating the system.

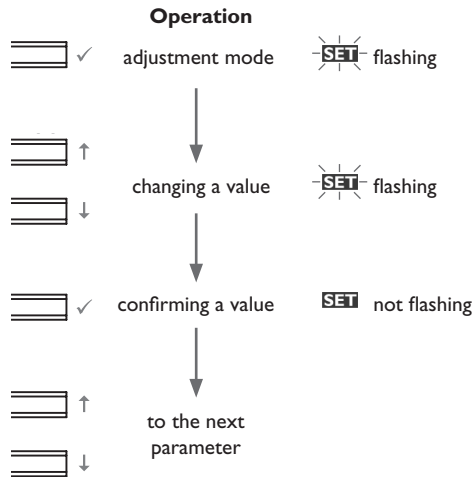

Commissioning

1. Language

➔ Adjust the desired menu language.

LANG

Language selection

Selection: dE, En, Fr, ES, It

Factory setting: dE

2. Temperature unit

➔ Adjust the desired unit.

UNIT

Temperature unit

Selection: °F, °C

Factory setting: °C

3. Time

➔ Adjust the clock time.

First of all adjust the hours, then the minutes.

TIME

Real time clock

4. Maximum store temperature

➔ Adjust the desired maximum store temperature.

S MX

Maximum store temperature

Adjustment range: 4... 95 °C [40... 200 °F]

Factory setting: 60 °C [140 °F]



Note:

The controller is also equipped with a non-adjustable emergency shutdown, deactivating the system if the store reaches 95 °C [200 °F].

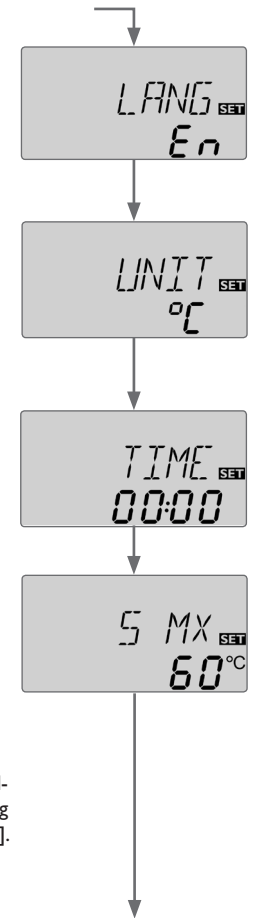

5. Pump control type

→ Adjust the pump control type.

PUM

Pump control type

Selection: OnOF, PULS, PSOL, PHEA

Factory setting: PSOL

The following types can be selected: Adjustment for standard pump without speed control

- OnOF (pump on/pump off)

Adjustment for standard pump with speed control

- PULS (burst control via semiconductor relay)

Adjustment for high-efficiency pump (HE pump)

- PSOL (PWM profile for a HE solar pump)
- PHEA (PWM profile for a HE heating pump)

6. Minimum speed

→ Adjust the minimum speed for the corresponding pump.

nMN

Minimum speed

Adjustment range: (10) 30... 100%

Factory setting: 30%



Note:

The pump speed must be set to 100% when auxiliary relays or valves are connected.

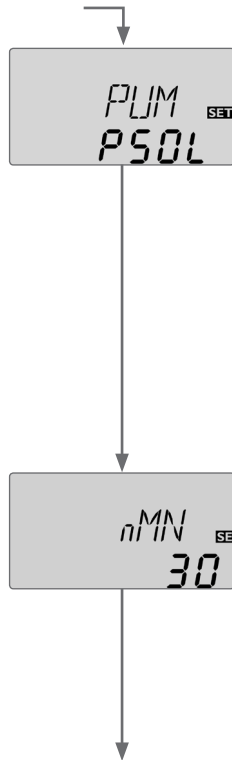

Commissioning

7. Maximum speed

→ Adjust the maximum speed for the corresponding pump.

nMX

Maximum speed

Adjustment range: (10) 30... 100%

Factory setting: 100%



Note:

The pump speed must be set to 100% when auxiliary relays or valves are connected.

8. PWM feedback signal

→ Adjust the PWM feedback signal type.

PFB

PWM feedback signal

Selection: OFF, A, b

Factory setting: OFF

(A = Wilo pump, b = Grundfos pump)

Confirmation

Completing the commissioning menu

After the last channel of the commissioning menu has been adjusted and confirmed, the controller asks for confirmation of the adjustments.

→ In order to confirm the adjustments made in the commissioning menu, press button ✓.

Now the controller is ready for operation.



Note:

The adjustments carried out during commissioning can be changed anytime in the corresponding adjustment channel. Additional functions and options can also be activated or deactivated (see page 20).

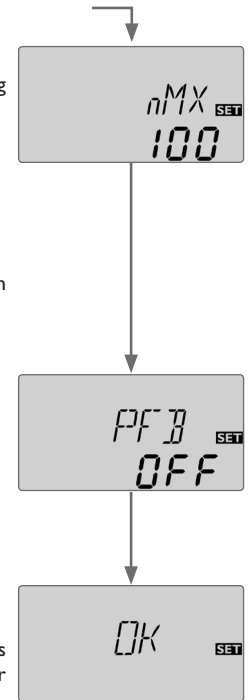

5 Control parameters and display channels

5.1 Channel overview

Display channels			
Channel	Description	Connection terminal	Page
INIT	x* ODB initialisation active	-	17
FLL	x* ODB filling time active	-	17
STAB	x* ODB stabilisation in progress	-	17
BOOS	x* Rapid heat-up active	-	17
DAYS	x* Holiday mode active	-	17
COL	x Temperature collector	S1	17
TST	s Temperature store 1 base (backup heating off)	S2	18
TSTB	x Temperature store 1 base	S2	18
TSTT	x Temperature store 1 top	S3	18
TDIS	s* Thermal disinfection temperature (thermal disinfection)	S3	18
S3	s Temperature store 1 top (backup heating off)	S3	18
S4	x Temperature sensor 4	S4	18
TFL	x* Temperature flow sensor	S1/S4/VFD	18
TR	x* Temperature return sensor	S4/VFD	18
VFD	x* Temperature Grundfos Direct Sensor™	VFD	18
L/h	x* Flow rate Grundfos Direct Sensor™ / PWM feedback signal	VFD/PWM	18
n%	x Speed R1	R1	18
h P1	x Operating hours R1	R1	20
h P2	x Operating hours R2	R2	20
kWh	x* Heat quantity in kWh	-	19
MWh	x* Heat quantity in MWh	-	19
CDIS	s* Countdown of monitoring period (thermal disinfection)	-	19
SDIS	s* Starting time display (thermal disinfection)	-	19
DDIS	s* Disinfection period display (thermal disinfection)	-	19
TIME	x Time	-	19

Adjustment channels			
Channel	Description	Factory setting	Page
DT O	x Switch-on temperature difference R1	6.0 K [12.0 °Ra]	20
DT F	x Switch-off temperature difference R1	4.0 K [8.0 °Ra]	20
DT S	x Set temperature difference R1	10.0 K [20.0 °Ra]	21
RIS	x Rise R1	2K [4 °Ra]	21
PUM	x Pump control type R1	PSOL	21
nMN	x Minimum speed R1	30%	21
nMX	x Maximum speed R1	100%	22
PFB	x* PWM feedback signal	OFF	22
S MX	x Maximum store temperature	60 °C [140 °F]	22
OSEM	x Store emergency shutdown option	OFF	23
EM	x Collector emergency temperature	130 °C [270 °F]	23
OCC	x Collector cooling option	OFF	23
CMX	x* Maximum collector temperature	110 °C [230 °F]	23
OSYC	x System cooling option	OFF	24
DTCO	x* Switch-on temperature difference cooling	20.0 K [40.0 °Ra]	24
DTCF	x* Switch-off temperature difference cooling	15.0 K [30.0 °Ra]	24
OSTC	x Store cooling option	OFF	24
OHOL	x* Holiday cooling option	OFF	24
THOL	x* Holiday cooling temperature	40 °C [110 °F]	24
OCN	x Collector minimum limitation option	OFF	25
CMN	x* Collector minimum temperature	10 °C [50 °F]	25
OCF	x Antifreeze option	OFF	25
CFR	x* Antifreeze temperature	4.0 °C [40.0 °F]	25
OTC	x Tube collector option	OFF	26
TCST	x* OTC starting time	07:00	26
TCEN	x* OTC ending time	19:00	26
TCRU	x* OTC runtime	30 s	26
TCIN	x* OTC standstill interval	30 min	26
GFD	x Grundfos Direct Sensor™	OFF	26
SEN	x* VFD allocation	2	27
FMAX	x* Maximum flow rate	6.0 l/min	27
MEDT	x Antifreeze type	1	28
MED%	x* Antifreeze concentration	45 %	28

Adjustment channels

Channel	Description	Factory setting	Page
BHMN	s Thermostat comfort temperature	40 °C [110 °F]	28
BH O	s Switch-on temperature for thermostat	40 °C [110 °F]	28
BHF	s Switch-off temperature for thermostat	45 °C [120 °F]	28
t1 O	s Thermostat switch-on time 1	00:00	28
t1 F	s Thermostat switch-off time 1	00:00	28
t2 O	s Thermostat switch-on time 2	00:00	28
t2 F	s Thermostat switch-off time 2	00:00	28
t3 O	s Thermostat switch-on time 3	00:00	28
t3 F	s Thermostat switch-off time 3	00:00	28
BOOS	s Rapid heat-up runtime	10 min	29
ODB	x Drainback option	OFF	29
tDTO	x* ODB switch-on condition - time period	60 s	30
tFLL	x* ODB filling time	5.0 min	30
tSTB	x* ODB stabilisation time	2.0 min	30
OTD	s Thermal disinfection option	OFF	30
PDIS	s* Monitoring period	01:00	30
DDIS	s* Disinfection period	01:00	30
TDIS	s* Disinfection temperature	60 °C [140 °F]	30
SDIS	s* Starting time	00:00	31
MAN1	x Manual mode R1	On	31
MAN2	x Manual mode R2	OFF	31
LANG	x Language	dE	32
UNIT	x Temperature unit	°C	32
RESE	x Reset - back to factory settings		32
#####	Version number		

Symbol	Description
--------	-------------

x	Channel is available
x*	Channel is available, if the corresponding option is activated.
s	System-specific channel
s*	System-specific channel, only available if the corresponding option is activated

6 Channel overview

6.1 Display channels



Note:

The display and adjustment channels as well as the adjustment ranges depend on the system selected, the functions and options as well as on the system components connected to the controller.

Display of drainback time periods

Initialisation

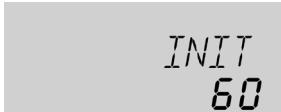

INIT

ODB initialisation active

Indicates the time adjusted in tD_{TO}, running backwards.

Filling time



FLL

ODB filling time active

Indicates the time adjusted in tF_{LL}, running backwards.

Stabilisation

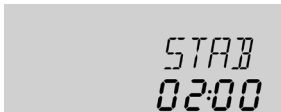

STAB

ODB stabilisation in progress

Indicates the time adjusted in tS_{TB}, running backwards.

Indication of rapid heat-up and days of absence

Rapid heat-up



BOOS

Rapid heat-up active

Indicates the time adjusted in BOOS, running backwards.

Days of absence



DAYS

Holiday mode active

Indicates the days adjusted, running backwards.

In this channel, the days of absence can also be adjusted.

Display of collector temperature



COL

Collector temperature

Display range: -40 ... +260 °C [-40 ... +500 °F]

Indicates the collector temperature.

Display of store temperatures

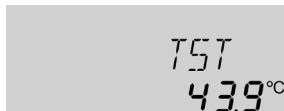

TST, TSTB, TSTT, TDIS

Store temperatures

Display range: -40 ... +260 °C [-40 ... +500 °F]

Indicates the store temperatures.

- TST : Store temperature (backup heating off)
- TSTB : Store temperature base
- TSTT : Store temperature top
- TDIS : Thermal disinfection temperature
(replaces TSTT if, during thermal disinfection, the disinfection period DDIS is active)

Display of sensors 3, 4 and VFD

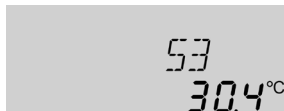

S3, S4, VFD

Sensor temperatures

Display range: -40 ... +260 °C [-40 ... +500 °F]

VFD: 0 ... 100 °C [32 ... 212 °F]

Indicates the current temperature at the corresponding additional sensor (without control function).

- S3 : Temperature at sensor 3 (backup heating off)
- S4 : Temperature at sensor 4
- VFD : Grundfos Direct Sensor™



Note:

S3 and S4 will only be indicated if the temperature sensors are connected to the corresponding terminals. VFD will be indicated only if a Grundfos Direct Sensor™ has been connected and registered.

Display of further temperatures



TFL, TR

Further measured temperatures

Display range: -40 ... +260 °C [-40 ... +500 °F]

Indicates the current temperature at the corresponding sensor.

- TFL : Temperature flow
- TR : Temperature return

Indication of the flow rate

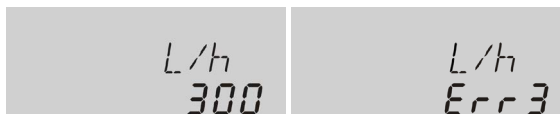

L/h

Flow rate/PWM feedback signal

Display range: depending on the sensor type used and the PWM feedback signal selected respectively

Indicates the current flow rate at the VFD flow rate sensor or of the bidirectional pump and its error messages respectively.

The display range depends on the sensor type selected.

Indication of current pump speed



n%

Current pump speed

Display range: 10 ... 100%

Indicates the current pump speed.

Display of heat quantity



kWh/MWh

Heat quantity in kWh/MWh

Display channel

Indicates the heat quantity produced in the system.

The heat quantity measurement can be carried out in 3 different ways (see page 27): with a fixed flow rate value, with a VFD Grundfos Direct Sensor™ or with a PWM feedback signal. It is shown in kWh in the channel kWh and in MWh in the channel MWh. The overall heat quantity results from the sum of both values.

The accumulated heat quantity can be set back to zero. As soon as one of the display channels of the heat quantity is selected, the symbol **SET** is displayed.

→ In order to access the reset mode of the counter, press button ✓ for approx. 2 s.

SET starts flashing and the heat quantity value will be set back to zero.

→ In order to finish the reset, press button ✓.

In order to interrupt the reset process, do not press any button for about 5 s. The display returns to the display mode.

Indication of thermal disinfection



CDIS

Countdown of the

Monitoring period

Display range: 0 ... 30:0 ... 24 (dd:hh)

If the thermal disinfection option (**OTD**) is activated and the monitoring period is in progress, the remaining time is displayed as **CDIS** (in hours and minutes), counting backwards.



SDIS

Display of starting time

Display range: 00:00 ... 24:00 (hh:mm)

If the thermal disinfection option (**OTD**) is activated and a starting delay time has been adjusted, the adjusted starting time is displayed as **SDIS** (flashing).

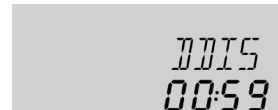

DDIS

Display of disinfection period

Display range: 00:00 ... 24:00 (hh:mm)

If the thermal disinfection option (**OTD**) is activated and the disinfection period is in progress, the remaining time is displayed as **CDIS** (in hours and minutes), counting backwards.

Display of time

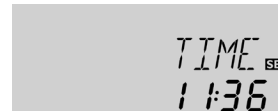

TIME

Indicates the current clock time.

→ In order to adjust the hours, press button ✓ for approx. 2 s.

→ Set the hours by pressing buttons ↑ and ↓.

→ In order to adjust the minutes, press button ✓.

→ Set the minutes by pressing buttons ↑ and ↓.

→ In order to save the adjustments, press button ✓.

Operating hours counter

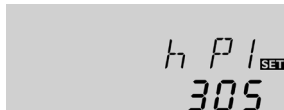

hP/hP1/hP2

Operating hours counter

Display channel

The operating hours counter accumulates the operating hours of the corresponding relays (**hP/hP1/hP2**). Only full hours are displayed.

The accumulated operating hours can be set back to zero. As soon as an operating hours channel is selected, the symbol **SET** is displayed.

→ In order to access the reset mode of the counter, press button ✓ for approx. 2s.

SET starts flashing and the operating hours value will be set back to zero.

→ In order to finish the reset, press button ✓.

In order to interrupt the reset process, do not press any button for about 5s. The display returns to the display mode.

6.2 Adjustment channels

ΔT control

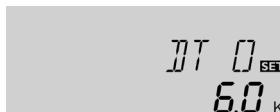

DTO

Switch-on temperature difference

Adjustment range: 1.0 ... 20.0 K [2.0 ... 40.0 °Ra]

Factory setting: 6.0 K [12.0 °Ra]

The controller works as a standard differential controller. If the temperature reaches or exceeds the switch-on temperature difference, the pump switches on.

When the temperature difference reaches or falls below the adjusted switch-off temperature difference, the respective relay switches off.



Note:

The switch-on temperature difference must be at least 0.5 K [1 °Ra] higher than the switch-off temperature difference.

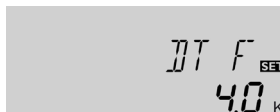

DTF

Switch-off temperature difference

Adjustment range: 0.5 ... 19.5 K [1.0 ... 39.0 °Ra]

Factory setting: 4.0 K [8.0 °Ra]



Note:

If the drainback option **ODB** is activated, the values of the parameters **DTO**, **DTF** and **DTS** will be adapted to values suiting drainback systems:

DTO = 10 K [20 °Ra]

DTF = 4 K [8 °Ra]

DTS = 15 K [30 °Ra]

Adjustments that have been previously made in these channels will be overridden and have to be entered again if **ODB** is deactivated later on.

Speed control



DT S

Set temperature difference

Adjustment range: 1.5 ... 30.0 K [3.0 ... 60.0 °Ra]

Factory setting: 10.0 K [20.0 °Ra]



RIS

Rise

Adjustment range: 1 ... 20 K [2 ... 40 °Ra]

Factory setting: 2 K [4 °Ra]



Note:

For pump speed control, the operating mode of the corresponding relay must be set to **Auto** (adjustment channel **MAN1** or slide switch position centre respectively).

If the temperature difference reaches or exceeds the switch-on temperature difference, the pump switches on at 100% speed for 10s. Then, the speed is reduced to the minimum pump speed value.

If the temperature difference reaches the adjusted set value, the pump speed increases by one step (10%). The response of the controller can be adapted via the parameter Rise. Each time the difference increases by the adjustable rise value, the pump speed increases by 10% until the maximum pump speed of 100% is reached. If the temperature difference decreases by the adjustable rise value, pump speed will be decreased by one step.



Note:

The set temperature difference must be at least 0.5 K [1 °Ra] higher than the switch-on temperature difference.



PUM

Pump control type

Selection: OnOF, PULS, PSOL, PHEA

Factory setting: PSOL

With this parameter, the pump control type can be adjusted. The following types can be selected:

Adjustment for standard pump without speed control

- OnOF (pump on/pump off)

Adjustment for standard pump with speed control

- PULS (burst control via semiconductor relay)

Adjustment for high-efficiency pump (HE pump)

- PSOL (PWM profile for a HE solar pump)
- PHEA (PWM profile for a HE heating pump)

Minimum speed



nMN

Minimum speed

Adjustment range: (10) 30 ... 100%

Factory setting: 30%

nMN, if ODB is activated: 50%

In the adjustment channel **nMN** a relative minimum speed for a pump connected can be allocated to the output R1.



Note:

The pump speed must be set to 100% when auxiliary relays or valves are connected.

Maximum speed



nMX

Maximum speed

Adjustment range: (10) 30 ... 100%

Factory setting: 100%

In the adjustment channel **nMX** a relative maximum speed for a pump connected can be allocated to the output R1.



Note:

The pump speed must be set to 100% when auxiliary relays or valves are connected.

PWM feedback signal



PFB

PWM feedback signal

Adjustment range: OFF, A, b

Factory setting: OFF

(A = Wilo pump, b = Grundfos pump)

With this parameter, the type of the PWM feedback signal of a bidirectional HE pump can be adjusted. The signal transmits either a flow rate between 0 ... 2100 l/h or an error message.

The following messages can be displayed:

Err1: PWM interface of the pump defective

Err2: The pump is not running optimally, external cause electronics (e. g. overvoltage, low voltage)

Err3: The pump stops, but is operable, external cause electronics (e. g. overvoltage, low voltage)

Err4: The pump stops, but is operable, external cause installation / hydraulics

Err5: The pump stops, but is not operable, internal cause electronics / pump is stuck

Err6: PWM feedback signal connection defective



Note

If there is an error, the flow rate will not be indicated and the heat quantity measurement will not be carried out.

Maximum store temperature



S MX

Maximum store temperature

Adjustment range: 4 ... 95 °C [40 ... 200 °F]

Factory setting: 60 °C [140 °F]

If the store temperature reaches the adjusted maximum temperature, the store will no longer be loaded in order to avoid damage caused by overheating. A non-adjustable hysteresis of 2K [4 °Ra] is set for the maximum store temperature.

If the maximum store temperature is exceeded, ☼ is displayed.



Note:

If the collector cooling or the system cooling function is activated, the adjusted maximum store temperature may be exceeded. In order to prevent system damage, the controller is also equipped with an integrated store emergency shutdown, deactivating the system if the store reaches 95 °C [200 °F].

Store emergency shutdown

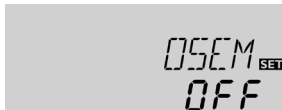

OSEM

Store emergency shutdown option

Adjustment range: OFF/ON

Factory setting: OFF

This option is used for activating the internal store emergency shutdown for an upper store sensor. If the temperature at the reference sensor exceeds 95 °C [200 °F], the store will be blocked and loading will be stopped until the temperature falls below 90 °C [190 °F].



Note:

S3 is used as the reference sensor.

Collector limit temperature

Collector emergency shutdown



EM

Collector limit temperature

Adjustment range: 80 ... 200 °C [170 ... 390 °F]

Factory setting: 130 °C [270 °F]

When the collector temperature exceeds the adjusted collector limit temperature, the solar pump (R1) switches off in order to protect the system components against overheating (collector emergency shutdown). If the collector limit temperature is exceeded, Δ is displayed.



Note:

If the drainback option **ODB** is activated, the adjustment range of **EM** is changed to 80 ... 120 °C [170 ... 250 °F]. The factory setting in that case is 95 °C [200 °F].

Cooling functions

In the following the 3 cooling functions – collector cooling, system cooling and store cooling – are described in detail. The following note is valid for all 3 cooling functions:



Note:

The cooling functions will not become active as long as solar loading is possible.

Collector cooling



OCC

Collector cooling option

Adjustment range: OFF/ON

Factory setting: OFF



CMX

Collector maximum temperature

Adjustment range: 70 ... 160 °C [150 ... 320 °F]

Factory setting: 110 °C [230 °F]

The collector cooling function keeps the collector temperature within the operating range by heating the store. If the store temperature reaches 95 °C [200 °F] the function will switch off for safety reasons.

If the store temperature exceeds the adjusted maximum store temperature, the solar system is switched off. If the collector temperature increases to the adjusted maximum collector temperature, the solar pump is activated until the collector temperature falls below the maximum collector temperature. The store temperature may then exceed the maximum store temperature, but only up to 95 °C [200 °F] (emergency shutdown of the store).

If the collector cooling function is active, \odot and \otimes are displayed (flashing).



Note:

This function will only be available if the system cooling function (**OSYC**) is deactivated.

System cooling



OSYC^{SET}
OFF

OSYC

System cooling option
Adjustment range: OFF/ON
Factory setting: OFF



DTCC^{SET}
20.0 K

DTCC

Switch-on temperature difference
Adjustment range: 1.0 ... 30.0 K [2.0 ... 60.0 °Ra]
Factory setting: 20.0 K [40.0 °Ra]

The system cooling function aims to keep the solar system operational for a longer time. The function overrides the maximum store temperature to provide thermal relief of the collector field and the heat transfer fluid on hot days. If the store temperature is higher than the adjusted maximum store temperature and the switch-on temperature difference **DTCC** is reached, the solar pump remains switched on or will be switched on. Solar loading is continued until either the temperature difference falls below the adjusted value **DTCC** or the collector limit temperature is reached. If the system cooling function is active, ☉ and ☼ are displayed (flashing).



DTCC^{SET}
15.0 K

DTCC

Switch-off temperature difference
Adjustment range: 0.5 ... 29.5 K [1.0 ... 59.0 °Ra]
Factory setting: 15.0 K [30.0 °Ra]



Note:

This function will only be available, if the collector cooling function (**OCC**) is deactivated.

Store cooling



OSTC^{SET}
OFF

OSTC

Store cooling option
Adjustment range: OFF/ON
Factory setting: OFF



OHOL^{SET}
OFF

OHOL

Holiday cooling option
Adjustment range: OFF/ON
Factory setting: OFF



THOL^{SET}
40 °C

THOL

Holiday cooling temperature
Adjustment range: 20 ... 80 °C [70 ... 175 °F]
Factory setting: 40 °C [110 °F]

When the store cooling function is activated, the controller aims to cool down the store during the night in order to prepare it for solar loading on the following day. If the adjusted maximum store temperature (**SMX**) is exceeded and the collector temperature falls below the store temperature, the system will be reactivated in order to cool down the store. Cooling will continue until the store temperature has fallen below the adjusted maximum store temperature (**SMX**) again. A hysteresis of 2 K [4 °Ra] is set for the store cooling function.

Reference threshold temperature differences for the store cooling function are **DTO** and **DTF**.

If no DHW consumption is expected for a longer period of time, the additional holiday cooling option **OHOL** can be activated in order to extend the store cooling function. The adjustable temperature **THOL** then replaces the maximum store temperature (**SMX**) as the switch-off temperature for the store cooling function.

When the holiday cooling function is activated, ☼ and ⚠ (flashing) are shown on the display.

If the holiday cooling function is active, ⓪, ☼ and ⚠ are displayed (flashing).



Note:

The holiday cooling will only become active when the holiday mode is triggered by means of button  (see page 12).

Minimum collector limitation

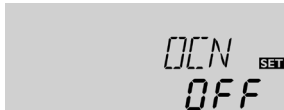

OCN

Collector minimum limitation option

Adjustment range: OFF/ON

Factory setting: OFF



CMN

Minimum collector temperature

Adjustment range: 10.0 ... 90.0 °C [50.0 ... 190.0 °F]

Factory setting: 10.0 °C [50.0 °F]

If the collector minimum limitation option is activated, the pump (R1) is only switched on if the adjustable collector minimum temperature is exceeded. The minimum temperature prevents the pump from being switched on too often at low collector temperatures. A hysteresis of 5 K [10 °Ra] is set for this function. If the collector minimum limitation is active, ☼ is displayed (flashing).



Note:

If **OSTC** or **OCF** is active, the collector minimum limitation will be overridden. In this case, the collector temperature may fall below **CMN**.

Antifreeze function



OCF

Antifreeze function option

Adjustment range: OFF/ON

Factory setting: OFF



CFR

Antifreeze temperature

Adjustment range: -40.0 ... +10.0 °C [-40.0 ... +50.0 °F]

Factory setting: +4.0 °C [+40.0 °F]

The antifreeze function activates the loading circuit between the collector and the store when the temperature falls below the adjusted antifreeze temperature. This will protect the fluid against freezing or coagulating. If the adjusted antifreeze temperature is exceeded by 1 K [2 °Ra], the loading circuit will be deactivated.

If the antifreeze function is activated, ☼ is displayed. If the antifreeze function is active, ⓪ and ☼ are displayed (flashing).



Note:

Since this function uses the limited heat quantity of the store, the antifreeze function should be used in regions with few days of temperatures around the freezing point.

The antifreeze function will be suppressed if the store temperature falls below +5 °C [+40 °F] in order to protect the store from frost damage.

Tube collector function



OTC

Tube collector option
Adjustment range: OFF/ON
Factory setting: OFF

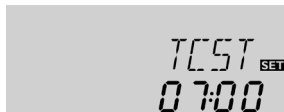

TCST

Tube collector function starting time
Adjustment range: 00:00 ... 23:45
Factory setting: 07:00

This function is used for improving the switch-on behaviour in systems with non-ideal sensor positions (e. g. with some tube collectors). This function operates within an adjusted time frame. It activates the collector circuit pump for an adjustable runtime between adjustable standstill intervals in order to compensate for the delayed temperature measurement.

If the runtime is set to more than 10 s, the pump will run at 100% for the first 10 s of the runtime. For the remaining runtime, the pump will be run at the adjusted minimum speed. If the collector sensor is defective or the collector is blocked, this function is suppressed or switched off.

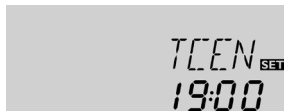

TCEN

Tube collector function ending time
Adjustment range: 00:00 ... 23:45
Factory setting: 19:00



TCRU

Tube collector function runtime
Adjustment range: 5 ... 500 s
Factory setting: 30 s



TCIN

Tube collector function standstill interval
Adjustment range: 1 ... 60 min
Factory setting: 30 min



Note:

If the drainback option **ODB** is activated, **TCRU** will not be available. In this case, the runtime will be determined by the parameters **tFLL** and **tSTB**.

Grundfos Direct Sensor™ registration



GFD

Grundfos Direct Sensor™ registration
Selection: OFF, 12, 40, 40F
Factory setting: OFF

Registration of a digital flow rate sensor which can be used for heat quantity measurement.

OFF : no Grundfos Direct Sensor™

12 : VFD 1-12 (water / propylene glycol mixture)

40 : VFD 2-40

40F : VFD 2-40 Fast (water only)

Heat quantity measurement

The heat quantity measurement can be carried out in 3 different ways (see below): with a fixed flow rate value, with a VFD Grundfos Direct Sensor™ or with a PWM feedback signal.

Heat quantity measurement with fixed flow rate value

The heat quantity balancing (estimation) uses the difference between the collector and the store base temperatures and the entered flow rate (at 100% pump speed).

- Read the flow rate (l/min) and adjust it in the **FMAX** channel.
- Adjust the antifreeze type and concentration of the heat transfer fluid in the channels **MEDT** and **MED%**.



FMAX

Flow rate in l/min

Adjustment range: 0.5 ... 100.0

Factory setting: 6.0



Note:

The **FMAX** channel will be available only if the **SEN** channel has been set to **OFF** or if no VFD Grundfos Direct Sensor™ is activated.

Heat quantity measurement with a VFD Grundfos Direct Sensor™

In order to use a VFD Grundfos Direct Sensor™ for heat quantity measurement, proceed as follows:

- Register the VFD Grundfos Direct Sensor™ in the **GFD** channel.
- Adjust the position of the **VFD Grundfos Direct Sensor™** in the **SEN** channel.
- Adjust the antifreeze type and concentration of the heat transfer fluid in the channels **MEDT** and **MED%**.

Heat quantity measurement with a PWM feedback signal

In order to use a VFD Grundfos Direct Sensor™ for heat quantity measurement, proceed as follows:

- Register the PWM feedback signal of a bidirectional HE pump on the **PFB** channel.
- Adjust the antifreeze type and concentration of the heat transfer fluid in the channels **MEDT** and **MED%**.

The VFD Grundfos Direct Sensor™ can optionally be used for measuring the temperature:

- Register the VFD Grundfos Direct Sensor™ in the **GFD** channel.
- Adjust the position of the VFD Grundfos Direct Sensor™ in the **SEN** channel.



Note

if a VFD Grundfos Direct Sensor™ is optionally activated, it will not be used for measuring the flow rate but for measuring the flow and return temperature respectively.



Note

If the PWM feedback signal sends an error message, heat quantity measurement will not be carried out.

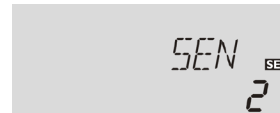

SEN

Digital flow rate sensor (only if GDF = 12, 40 or 40 F)

Selection: OFF, 1, 2

Factory setting: 2

Flow rate detection type:

OFF : PWM feedback signal or fixed flow rate value (flowmeter)

- 1 : PWM feedback signal or Grundfos Direct Sensor™ in the flow pipe
- 2 : PWM feedback signal or Grundfos Direct Sensor™ in the return pipe

Sensor allocation for heat quantity measurement:

1		2		OFF	
SFL	SRET	SFL	SRET	SFL	SRET
GFD	S4	S1	GFD	S1	S2



MEDT

Heat transfer fluid
Adjustment range: 0 ... 3
Factory setting: 1

Heat transfer fluid:

0 : Water
1 : Propylene glycol
2 : Ethylene glycol
3 : Tyfocor® LS / G-LS



MED%

Antifreeze concentration
in Vol-% (MED% is not indicated when MEDT 0 or 3 is used.)
Adjustment range: 20 ... 70%
Factory setting: 45%

Thermostat function for backup heating



Note:

The thermostat function is only available when the slide switch is in the centre position.



BH O

Thermostat switch-on temperature
Adjustment range:
0 ... 95 °C [30 ... 200 °F]
Factory setting: 40 °C [110 °F]

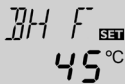

BH F

Thermostat switch-off temperature
Adjustment range:
0 ... 95 °C [30 ... 200 °F]
Factory setting: 45 °C [120 °F]



Note:

The thermostat switch-on temperature can only be lower than or equal to the thermostat switch-off temperature.

The thermostat function can be used for backup heating. S3 is used as the reference sensor.

If the temperature falls below the thermostat switch-on temperature BH O, relay R2 is energised for backup heating. If the thermostat switch-off temperature BH F is exceeded, the relay switches off.

The thermostat function is deactivated, if the thermostat switch-on temperature and the thermostat switch-off temperature are set to an identical value.



Note:

When the holiday mode is active, the thermostat function will be suppressed.

Backup heating suppression



BHMN

Comfort temperature
Adjustment range: 0.0 ... 95.0 °C [30.0 ... 200.0 °F]
Factory setting: 40.0 °C [110.0 °F]

When solar loading is in progress, backup heating will be suppressed until the temperature at S3 falls below the comfort temperature **BHMN**.

When **BHMN** and **BHO** are set to identical values, the function will be deactivated.



t1 (2,3) O

Thermostat switch-on time
Adjustment range: 00:00 ... 23:45
Factory setting: 00:00



t1 (2,3) F

Thermostat switch-off time
Adjustment range: 00:00 ... 23:45
Factory setting: 00:00

In order to block the thermostat function for a certain period, there are 3 time frames t1 ... t3. The switch-on and switch-off times can be adjusted in steps of 15 min.

If the thermostat function is supposed to run from 06:00 a.m. to 09:00 a.m. only, adjust t1 O to 06:00 a.m. and t1 F to 09:00 a.m.

If the switch-on and switch-off times of a time frame are set to an identical value, the time frame will be inactive.

If all time frames are set to 00:00, the thermostat function is solely temperature dependent (factory setting).

Rapid heat-up

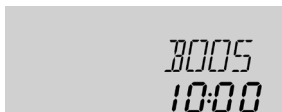

BOOS

Rapid heat-up runtime

Adjustment range: 0 ... 120 min

Factory setting: 10 min

Adjustment of the maximum runtime for the rapid heat-up to be active.

Rapid heat-up enables immediate heating of the store even outside the adjusted time frames.

If rapid heat-up is activated, the controller will switch on the backup heating of the store. Rapid heat-up of the store will stop if the switch-off temperature BH F is reached at sensor S3.

→ In order to activate the rapid heat-up, scroll to the first display channel, press and hold down button  for 3 s. It is also possible to press the button of the RCTT Remote control (accessory) instead.



→ In order to deactivate the rapid heat-up, press and hold down the upper controller button again for 3 s. It is also possible to press the button of the RCTT Remote control again instead.



Note:

If the temperature at sensor S3 exceeds the adjusted switch-off temperature BH F while rapid heat-up is being activated, **rapid heat-up** will be blocked.

Drainback option



Note:

A drainback system requires additional components such as a holding tank. The drainback option should only be activated if all components required are properly installed.

In a drainback system, the heat transfer fluid will flow into a holding tank if solar loading does not take place. The drainback option initiates the filling process if solar loading is about to start. If the drainback option is activated, the following adjustment can be made.

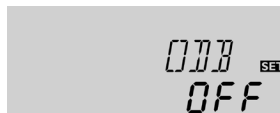

ODB

Drainback option

Adjustment range: OFF/ON

Factory setting: OFF



Note:

If the drainback option is activated, the cooling functions and the anti-freeze function will not be available. If one or more than one of these functions have been activated before, they will be deactivated again as soon as **ODB** is activated. They will remain deactivated, even if **ODB** is deactivated later on.



Note:

If the drainback function **ODB** is activated, the factory settings of the parameters **nMN**, **DT O**, **DT F** and **DTS** will be adapted to values suiting drainback systems.

Additionally, the adjustment range and the factory setting of the collector emergency shutdown will change. Adjustments previously made in these channels will be overridden and have to be entered again if the drainback option is deactivated later on.

Time period – switch-on condition

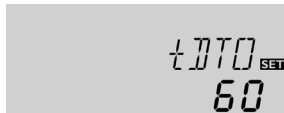

tDTC

Time period – switch-on condition

Adjustment range: 1 ... 100 s

Factory setting: 60 s

The parameter **tDTC** is used for adjusting the time period during which the switch-on condition must be permanently fulfilled.

Filling time



tFLL

Filling time

Adjustment range: 1.0 ... 30.0 min

Factory setting: 5.0 min

The filling time can be adjusted using the parameter **tFLL**. During this period, the pump runs at 100% speed.

Stabilisation

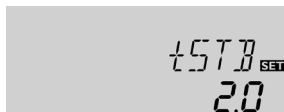

tSTB

Stabilisation

Adjustment range: 1.0 ... 15.0 min

Factory setting: 2.0 min

The parameter **tSTB** is used for adjusting the time period during which the switch-off condition will be ignored after the filling time has ended.

Thermal disinfection of the upper DHW zone



OTD

Therm. disinfection function

Adjustment range: OFF/ON

Factory setting: OFF

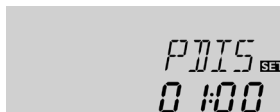

PDIS

Monitoring period

Adjustment range: 0 ... 30:0 ... 24 h (dd:hh)

Factory setting: 01:00

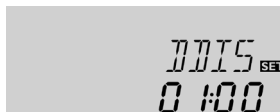

DDIS

Disinfection period

Adjustment range: 0:00 ... 23:59 (hh:mm)

Factory setting: 01:00

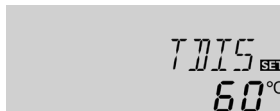

TDIS

Disinfection temperature

Adjustment range: 0 ... 95 °C [30 ... 200 °F]

Factory setting: 60 °C [140 °F]

Reference sensor for this function is S3. R2 is the reference relay.

This function helps to contain the spread of Legionella in DHW stores by systematically activating the backup heating.

For thermal disinfection, the temperature at the reference sensor will be monitored. Protection is ensured when, during the monitoring period, the disinfection temperature is continuously exceeded for the entire disinfection period.

The monitoring period starts as soon as the temperature at the reference sensor falls below the disinfection temperature. When the monitoring period ends, the allocated reference relay activates the backup heating. The disinfection period starts, if the temperature at the allocated sensor exceeds the disinfection temperature.

Thermal disinfection can only be completed when the disinfection temperature is exceeded for the duration of the disinfection period without any interruption.

Starting time delay



SDIS

Starting time

Adjustment range: 0:00 ... 24:00 (time)

Factory setting: 00:00

If the starting delay option is activated, a starting time for the thermal disinfection with starting delay can be adjusted. The activation of the backup heating is then delayed until that starting time after the monitoring period has ended.

If the monitoring period ends, for example, at 12:00 o'clock, and the starting time has been set to 18:00, the reference relay will be energised with a delay of 6 hours at 18:00 instead of 12:00 o'clock.



Note:

If the thermal disinfection option is activated, the display channels **TDIS**, **CDIS**, **SDIS** and **DDIS** will be displayed.



Note:

The thermal disinfection function is only available when the slide switch is in the centre position.

The function can also become active during holiday mode.

Operating mode



MAN1/MAN2

Operating mode

Adjustment range: OFF, Auto, On

Factory setting: R1: On, R2: OFF





For control and service work, the operating mode of the relays can be manually adjusted. For this purpose, select the adjustment value **MAN1** (for R1) or **MAN2** (for R2) in which the following adjustments can be made:

• MAN1/MAN2

Operating mode

OFF : Relay off  (flashing) + 

Auto : Relay in automatic operation

ON : Relay on  (flashing) +  +  / 



Note:

Always adjust the operating mode back to **Auto** when the control and service work is completed. Normal operation is not possible in manual mode.

If the slide switch is in the right-hand position, manual mode will become active with the adjustments made previously. The parameters **MAN1/MAN2** can be accessed directly via the shortcut (see page 12).

Language



LANG

Language selection

Selection: dE, En, Fr, ES, It

Factory setting: dE

In this adjustment channel the menu language can be selected.

- dE : German
- En : English
- Fr : French
- ES : Spanish
- It : Italian

Unit



UNIT

Temperature unit selection

Selection: °F, °C

Factory setting: °C

In this adjustment channel, the display unit for temperatures and temperature differences can be selected. The unit can be switched between °C/K and °F/°Ra during operation.

Temperatures and temperature differences in °F and °Ra are displayed without units. If the indication is set to °C, the units are displayed with the values.

Reset



RESE

Reset function

By means of the reset function, all adjustments can be set back to their factory settings.

→ In order to carry out a reset, press button ✓.

All adjustments that have previously been made will be lost! For this reason, a security enquiry will appear after the reset function has been selected.

Only confirm the security enquiry if you are sure you want to set back all adjustment to the factory setting.

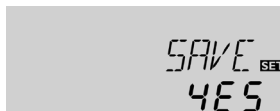

Security enquiry

→ In order to confirm the security enquiry, press button ✓.



Note:

After a reset, the commissioning menu will start again (see page 13).

7 RCTT Remote control (accessory)



The RCTT Remote control enables rapid heat-up activation via the button without having to access the controller menu. It is connected to the controller with a 3-wire cable (see page 6).

If the button of the RCTT is pressed, rapid heat-up will be activated on the controller. If rapid heat-up is already active, it will be deactivated.

If rapid heat-up is active on the controller, the LED of the RCTT will be permanently red.

If rapid heat-up is not possible, because the temperature at sensor S3 has exceeded the switch-off temperature BH F, the LED of the RCTT will briefly flash 3 times.

In the case of a sensor fault, the LED of the RCTT will be flashing continuously.

The RCTT Remote control has to be connected to the controller according to the installation instructions mentioned in the RCTT Remote control manual.

8 Troubleshooting

WARNING! Electric shock!



Upon opening the housing, live parts are exposed!

→ **Always disconnect the device from power supply before opening the housing!**

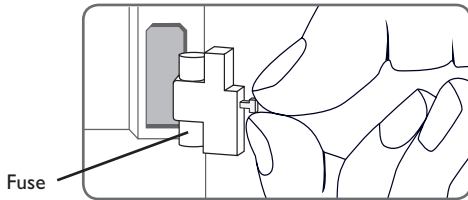

The controller is protected by a fuse. The fuse holder (which also holds the spare fuse) becomes accessible when the cover is removed. To replace the fuse, pull the fuse holder from the base.



Note

For answers to frequently asked questions (FAQ) see www.resol.com.

If a malfunction occurs, the display symbols will indicate an error code (see page 11).

Operating control LED flashes red. The symbol  is indicated on the display and the symbol  is flashing.

Sensor fault. An error code instead of a temperature is shown on the sensor display channel.

888.8

- 88.8

Cable is broken. Check the cable.

Short circuit. Check the cable.

Disconnected temperature sensors can be checked with an ohmmeter. Please check if the resistance values correspond with the table.

°C	°F	Ω Pt1000	°C	°F	Ω Pt1000
-10	14	961	55	131	1213
-5	23	980	60	140	1232
0	32	1000	65	149	1252
5	41	1019	70	158	1271
10	50	1039	75	167	1290
15	59	1058	80	176	1309
20	68	1078	85	185	1328
25	77	1097	90	194	1347
30	86	1117	95	203	1366
35	95	1136	100	212	1385
40	104	1155	105	221	1404
45	113	1175	110	230	1423
50	122	1194	115	239	1442

Resistance values of Pt1000 sensors

Operating control LED is permanently off

If the operating control LED is off, check the power supply of the controller. Is it disconnected?

no

yes

The fuse of the controller could be blown. The fuse holder (which holds the spare fuse) becomes accessible when the cover is removed. The fuse can then be replaced.

Check the supply line and reconnect it.

Pump is overheated, but no heat transfer from the collector to the store, flow and return have the same temperature; perhaps also bubbling in the lines.

Air or gas bubbles in the system?

no

yes

Is the collector circuit blocked at the dirt trap?

yes

Vent the system; increase the system pressure to a static primary pressure of at least plus 0.5 bar; if necessary continue to increase pressure; switch the pump on and off for a short time.

Clean dirt trap

Pump starts for a short moment, switches off, switches on again, etc.

Temperature difference at the controller too small?

no

yes

Wrong position of collector sensors?

no

yes

Plausibility control of the option tube collector special function

Change ΔT_{on} and ΔT_{off} correspondingly.

no

o.k.

Mount the collector sensor at solar flow (warmest collector output); use immersion sleeve of the respective collector.

Pump starts up very late.

Switch-on temperature difference ΔT_{on} too large?

no

yes

Change ΔT_{on} and ΔT_{off} correspondingly.

Non-ideal position of the collector sensor (e. g. flatscrew sensor instead of sensor in immersion sleeves).

yes

Activate tube collector function if necessary.

o.k.

The temperature difference between store and collector increases enormously during operation; the collector circuit cannot dissipate the heat

Collector circuit pump defective?

no

yes

Check / replace it

Heat exchanger calcified?

no

yes

Decalcify it

Heat exchanger blocked?

no

yes

Clean it

Heat exchanger too small?

yes

Replace with correctly sized one.

The solar circuit pump does not work, although the collector is considerably warmer than the store

Is the operating control LED on?

yes no

There is no current; check fuses/replace them and check power supply.

Does the pump start up in manual operation?

no yes

The adjusted temperature difference for starting the pump is too high; choose a value which makes more sense.

Is the pump current enabled by the controller?

no yes

Is the pump stuck?

yes

Is the fuse of the controller OK?

no yes

Turn the pump shaft using a screwdriver; now passable?

no

Replace the fuse.

Controller might be defective - replace it.

Pump is defective - replace it.

Store cools down at night.

Collector circuit pump runs during the night?

no yes

Check controller

Collector temperature at night is higher than the outdoor temperature.

no yes

Check the non-return valves in the flow and the return pipe for functional efficiency.

Sufficient store insulation?

yes no

Increase insulation.

a

Insulation close enough to the store?

yes no

Replace insulation or increase it.

Are the store connections insulated?

yes no

Insulate the connections.

Warm water outflow upwards?

no yes

Change connection and let the water flow sideways or through a siphon (downwards); less store losses now?

no yes

o.k.

Does the DHW circulation run for a very long time?

no yes

Use the circulation pump with timer and switch-off thermostat (energy-efficient circulation).

Circulation pump and blocking valve should be switched off for 1 night; less store losses?

yes no

Check whether the pumps of the backup heating circuit run at night; check whether the non-return valve is defective; problem solved?

no

Check the non-return valve in warm water circulation - o.k.

yes no

Further pumps which are connected to the solar store must also be checked.

Clean or replace it.

The gravitation circulation in the circulation line is too strong; insert a stronger valve in the non-return valve or an electrical 2-port valve behind the circulation pump; the 2-port valve is open when the pump

is activated, otherwise it is closed; connect pump and 2-port valve electrically in parallel; activate the circulation again. Deactivate pump speed control!

a

9 Accessories



Sensors



Overvoltage protection device



RCTT Remote control



VBus®/USB & VBus®/LAN interface adapters



SD3 Smart Display/
GA3 Large Display



AM1 Alarm module



KM1 Communication module



DL2 Datalogger



DL3 Datalogger

9.1 Sensors

Sensors

The product range includes high-precision platinum temperature sensors, flatscrew sensors, outdoor temperature sensors, indoor temperature sensors, cylindrical clip-on sensors, also as complete sensors with immersion sleeve.

Overvoltage protection device

In order to avoid overvoltage damage at collector sensors (e. g. caused by local lightning storms), we recommend installing the overvoltage protection RESOL SP10.

9.2 VBus® accessories

SD3 Smart Display/ GA3 Large Display

The remote displays are used for visualising data issued by the controller: collector temperature, store temperature and energy yield of the solar thermal system. The use of high-efficiency LEDs and filter glass assures a high optical brilliance and good readability even in poor visibility conditions and from a larger distance. Both remote displays are connected to the controller by means of the RESOL VBus®.

AM1 Alarm module

The AM1 Alarm module is designed to signal system failures. It is to be connected to the VBus® of the controller and issues an optical signal via the red LED if a failure has occurred. The AM1 also has a relay output, which can e. g. be connected to a building management system (BMS). Thus, a collective error message can be issued in the case of a system failure.

VBus®/LAN interface adapter

The VBus®/LAN interface adapter is designed for the direct connection of the controller to a PC or router. It enables easy access to the controller via the local network of the owner. Thus, controller access and data charting can be effected from every workstation of the network. The VBus®/LAN interface adapter is suitable for all controllers equipped with a RESOL VBus®. The RESOL ServiceCenter software is included.

DL2 Datalogger

This additional module enables the acquisition and storage of large amounts of data (such as measuring and balance values of the solar system) over a long period of time. System access is possible with just a few clicks via the VBus.net Internet portal. For transmission of the data stored in the internal memory of the DL2 to a PC, an SD card can be used. The DL2 is appropriate for all controllers with RESOL VBus®. The datalogger can be connected directly to a PC or router for remote enquiry and thus enables comfortable system monitoring for yield monitoring or for diagnostics of faults.

DL3 Datalogger

Be it solar thermal, heating or DHW heat exchange controllers – with the DL3 you can easily and conveniently log system data of up to 6 RESOL controllers. Get a comprehensive overview of all controllers connected with the large full graphic display. Transfer data with an SD memory card, or use the LAN interface to view and process data on your PC.

KM1 Communication module

The KM1 Communication module is the network connection for solar and heating systems, especially suited for technicians managing large systems, heating installers and home owners who like to keep a close eye on their system. VBus.net enables e. g. controlling the system yield in a comprehensive system scheme image.

RCTT Remote control

The RCTT Remote control enables rapid heat-up activation via the button without having to access the controller menu (see page 33).

VBus.net

The Internet portal for easy and secure access to your system data. VBus.net is all about the data of your RESOL controller. Live data of your system, customized filter settings and much more await you.

A		O	
Accessories.....	37	Operating hours counter	20
Antifreeze function	25	P	
B		Pump control type	21
Backup heating.....	28	PWM feedback	22
Backup heating suppression.....	28	PWM interface.....	7
C		PWM signal.....	7
Cable link	8	R	
Collector cooling.....	23	Rapid heat-up.....	12
Collector emergency shutdown.....	23	Remote control	33
Commissioning	13	Reset	32
Cooling function.....	23	S	
D		Sensor.....	6
ΔT control.....	20	Shortcut	12
Display	10, 17	Slide switch.....	12
Drainback option	29	Speed control.....	21
F		Store cooling.....	24
Flashing codes	12	System screen.....	11
Flow rate.....	18, 27	T	
G		Temperature differential control (ΔT control).....	20
Grundfos Direct Sensor™	26	Thermal disinfection.....	30
H		Thermostat function	28
Heat quantity measurement.....	27	Time	13, 19
Holiday.....	12, 24	Tool bar	11
L		Troubleshooting.....	34
Language.....	32	Tube collector function.....	26
M		V	
Manual mode.....	12, 31	VBus®	7
Minimum collector temperature	25		

Distributed by:

RESOL – Elektronische Regelungen GmbH

Heiskampstraße 10

45527 Hattingen / Germany

Tel.: +49 (0) 23 24 / 96 48 - 0

Fax: +49 (0) 23 24 / 96 48 - 755

www.resol.com

info@resol.com

Important note

The texts and drawings in this manual are correct to the best of our knowledge. As faults can never be excluded, please note:

Your own calculations and plans, under consideration of the current standards and directions should only be basis for your projects. We do not offer a guarantee for the completeness of the drawings and texts of this manual - they only represent some examples. They can only be used at your own risk. No liability is assumed for incorrect, incomplete or false information and/or the resulting damages.

Note

The design and the specifications can be changed without notice.

The illustrations may differ from the original product.

Imprint

This mounting- and operation manual including all parts is copyrighted. Another use outside the copyright requires the approval of RESOL – Elektronische Regelungen GmbH. This especially applies for copies, translations, micro films and the storage into electronic systems.

© **RESOL – Elektronische Regelungen GmbH**