

DeltaSol® BX

from version 3.01

RESOL®

Solar controller

Manual for the
specialised craftsman

Installation

Operation

Functions and options

Troubleshooting



11209187



The Internet portal for easy and secure access
to your system data – www.vbus.net

Thank you for buying this RESOL product.
Please read this manual carefully to get the best performance from this unit.
Please keep this manual carefully.

en

Manual

www.resol.com

Safety advice

Please pay attention to the following safety advice in order to avoid danger and damage to people and property.

Instructions

Attention must be paid to the valid local standards, regulations and directives!

Information about the product

Proper usage

The solar controller is designed for electronically controlling standard solar thermal systems and heating systems in compliance with the technical data specified in this manual.

Improper use excludes all liability claims.

EU declaration of conformity

The product complies with the relevant directives and is therefore labelled with the CE mark. The Declaration of Conformity is available upon request, please contact RESOL.



Note:

Strong electromagnetic fields can impair the function of the controller.

- Make sure the controller as well as the system are not exposed to strong electromagnetic fields.

Target group

These instructions are exclusively addressed to authorised skilled personnel.

Only qualified electricians should carry out electrical works.

Initial installation must be effected by the system owner or qualified personnel named by the system owner.

Description of symbols

WARNING! Warnings are indicated with a warning triangle!



→ **They contain information on how to avoid the danger described.**

Signal words describe the danger that may occur, when it is not avoided.

- **WARNING** means that injury, possibly life-threatening injury, can occur.
- **ATTENTION** means that damage to the appliance can occur.



Note:

Notes are indicated with an information symbol.

- Arrows indicate instruction steps that should be carried out.

Disposal

- Dispose of the packaging in an environmentally sound manner.
- Dispose of old appliances in an environmentally sound manner. Upon request we will take back your old appliances bought from us and guarantee an environmentally sound disposal of the devices.

Subject to technical change. Errors excepted.

With its versatile software, the DeltaSol® BX can control even complex systems easily and reliably. The DeltaSol® BX is equipped with 26 pre-programmed basic systems for a broad range of 1- and 2-store systems. Pre-defined functions facilitate system parameterisation.

The integrated SD card slot enables an easy datalogging to an SD card as well as a quick and effortless transfer of logged system data to a PC. The extra-large display vouches for a precise visualisation of the system status.

Contents

1 Overview	4	5 Status level / Measurement values	38
2 Installation	5	6 Commissioning	39
2.1 Mounting	5	7 Indications, functions and options	41
2.2 Electrical connection	5	7.1 Status level	41
2.3 Data communication / Bus	6	7.2 Menu overview	45
2.4 SD memory card slot	6	8 User code and short menu – Adjustment values	68
2.5 System overview	7	9 Messages	68
2.6 Systems	9	10 Troubleshooting	69
3 Operation and function	35	11 Accessories	72
3.1 Buttons	35	11.1 Sensors and measuring instruments	73
3.2 Menu structure	36	11.2 VBus® accessories	73
3.3 Selecting menu points and adjusting values	36	11.3 Interface adapters	73
4 System-Monitoring-Display	36	12 Index	74
4.1 System screen	37		
4.2 Further indications	37		

1 Overview

- 4 relay outputs, 5 Pt1000 temperature sensor inputs
- 2 inputs for analogue Grundfos Direct Sensors™ temperature sensors
- 2 PWM outputs for speed control of high-efficiency pumps
- 26 basic systems to choose from
- Drainback option
- Unit °F and °C selectable

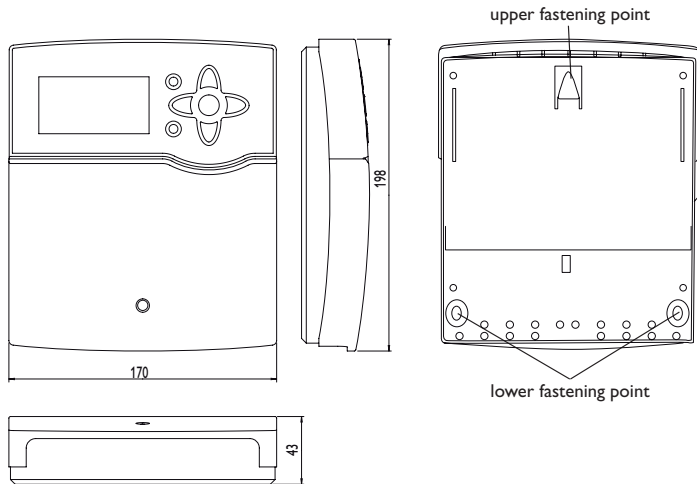

Technical data

Inputs: 5 inputs for Pt1000 temperature sensors, 2 analogue Grundfos Direct Sensors™, 1 V40 impulse input,

Outputs: 3 semiconductor relays, 1 electromechanical relay, 2 PWM outputs

Switching capacity:

1 (1) A 240V~ (semiconductor relay)

2 (1) A 240V~ (electromechanical relay)

Total switching capacity: 4 A 240V~

Power supply: 100 ... 240V~ (50 ... 60 Hz)

Supply connection: type Y attachment

Standby: 0.57 W

Temperature controls class: I

Energy efficiency [%]: 1

Mode of operation: type 1.B.C.Y action

Rated impulse voltage: 2.5 kV

Data interface: RESOLVBus®, SD card slot

VBus® current supply: 35 mA

Functions: function control, operating hours counter, tube collector function, thermostat function, speed control, heat quantity measurement, etc.

Housing: plastic, PC-ABS and PMMA

Mounting: wall mounting, also suitable for mounting into patch panels

Indication / Display: System-Monitoring-Display, for visualisation of the systems, 16-segment display, 7-segment display, 8 symbols, operating control LED (directional pad) and background illumination

Operation: 7 push buttons at the front of the housing

Protection type: IP 20 / DIN EN 60529

Protection class: I

Ambient temperature: 0 ... 40 °C

Degree of pollution: 2

Dimensions: 198 x 170 x 43 mm

2 Installation

2.1 Mounting

WARNING! Electric shock!



Upon opening the housing, live parts are exposed!
→ **Always disconnect the device from power supply before opening the housing!**



Note:

Strong electromagnetic fields can impair the function of the controller.
→ Make sure the controller as well as the system are not exposed to strong electromagnetic fields.

The unit must only be located in dry interior rooms.

The controller must additionally be supplied from a double pole switch with contact gap of at least 3 mm.

Please pay attention to separate routing of sensor cables and mains cables.

In order to mount the device to the wall, carry out the following steps:

- Unscrew the crosshead screw from the cover and remove it along with the cover from the housing.
- Mark the upper fastening point on the wall. Drill and fasten the enclosed wall plug and screw leaving the head protruding.
- Hang the housing from the upper fastening point and mark the lower fastening points (centres 150 mm).
- Insert lower wall plugs.
- Fasten the housing to the wall with the lower fastening screw and tighten.
- Carry out the electrical wiring in accordance with the terminal allocation (see chap. 2.2).
- Put the cover on the housing.
- Attach with the fastening screw.

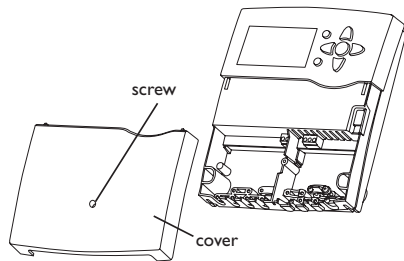

2.2 Electrical connection

WARNING! Electric shock!



Upon opening the housing, live parts are exposed!
→ **Always disconnect the device from power supply before opening the housing!**

ATTENTION! ESD damage!



Electrostatic discharge can lead to damage to electronic components!
→ **Take care to discharge properly before touching the inside of the device! To do so, touch a grounded surface such as a radiator or tap!**



Note:

Connecting the device to the power supply must always be the last step of the installation!



Note:

The pump speed must be set to 100% when auxiliary relays or valves are connected.

The controller is supplied with power via a mains cable. The power supply of the device must be 100 ... 240 V~ (50 ... 60 Hz).

The controller is equipped with 4 relays in total to which loads such as pumps, valves, etc. can be connected:

- Relays 1 ... 3 are semiconductor relays, designed for pump speed control.
 - Conductor R1 ... R3
 - Neutral conductor N
 - Protective conductor ⊕
- Relay 4 is an electromechanical relay
 - Conductor R4
 - Neutral conductor N
 - Protective conductor ⊕

Depending on the product version, mains cables and sensor cables are already connected to the device. If that is not the case, please proceed as follows:

Connect the **temperature sensors** (S1 to S5) to the corresponding terminals with either polarity:

S1 = Sensor 1 (collector sensor)

S2 = Sensor 2 (store sensor base)

S3 = Sensor 3 (e.g. store sensor top)

S4 = Sensor 4 (e.g. store sensor store 2)

S5 = Sensor 5 (e.g. sensor collector 2)

Connect the **Grundfos Direct Sensors™** to the inputs marked VFS and RPS.

A **V40** flowmeter can be connected to the terminals V40 and GND (either polarity).

The terminals marked PWM are control outputs for high-efficiency pumps (PWM1 is allocated to R1, PWM2 is allocated to R2).

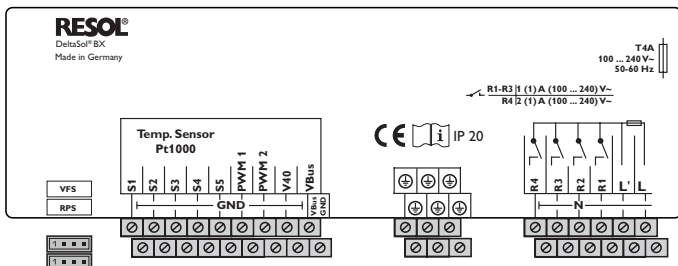

The **mains connection** is at the terminals:

Neutral conductor N

Conductor L

Conductor L' (L' is not connected with the mains cable. L' is a fused contact permanently carrying voltage.)

Protective conductor ⊕



Note:

For further information about heat quantity measurement with Grundfos Direct Sensors™ see page 64.



Note:

The connection depends on the system layout selected (see page 7).



Note:

For more details about the commissioning procedure see page 39.

2.3 Data communication/Bus

The controller is equipped with a RESOL **VBus®** for data transfer and energy supply to external modules. The connection is to be carried out at the terminals marked **VBus** (either polarity).

One or more RESOL **VBus®** modules can be connected via this data bus, such as:

- RESOL GA3 Large Display module/SD3 Smart Display
- RESOL AM1 Alarm Module
- RESOL DL2 Datalogger
- RESOL DL3 Datalogger

Furthermore, the controller can be connected to a PC or integrated into a network via the RESOL VBus®/USB or VBus®/LAN interface adapter (not included). Different solutions for visualisation and remote parameterisation are available on the RESOL website www.resol.com.



Note:

More accessories on page 72.

2.4 SD memory card slot

The controller is equipped with an SD card slot.

With an SD card, the following functions can be carried out:

- Store measurement and balance values onto the SD card. After the transfer to a computer, the values can be opened and visualised, e.g. in a spreadsheet.

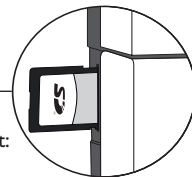

Note:

For more information about using an SD card, see page 66.

2.5 System overview

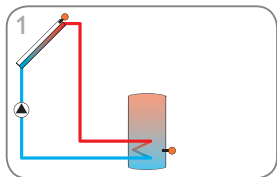

Solar system with 1 store (page 9)

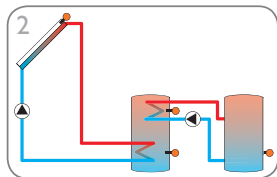

Solar system with 2 stores and heat exchange (page 10)

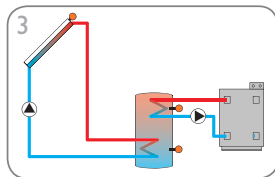

Solar system with 1 store and backup heating (page 11)

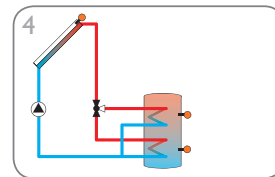

Solar system with 1 store and 3-port valve for store loading in layers (page 11)

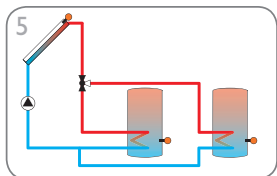

Solar system with 2 stores and valve logic (page 13)

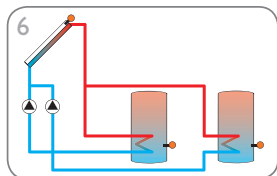

Solar system with 2 stores and pump logic (page 14)

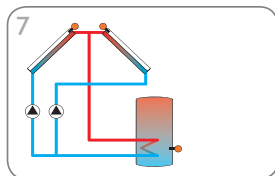

Solar system with east-/west collectors (page 15)

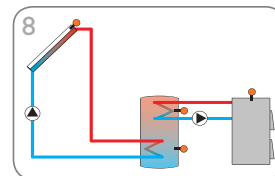

Solar system with 1 store and solid fuel boiler (page 16)

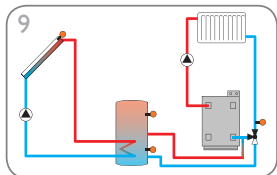

Solar system with 1 store and return preheating (page 17)

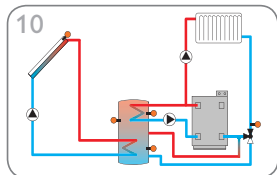

Solar system with 1 store, return preheating and backup heating (page 18)

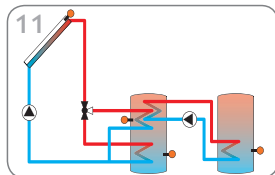

Solar system with store loading in layers and heat exchange (page 19)

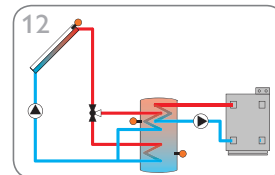

Solar system with store loading in layers and backup heating (page 20)

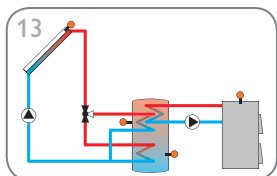

Solar system with store loading in layers and solid fuel boiler (page 21)

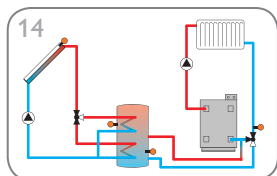

Solar system with store loading in layers and return preheating (page 22)

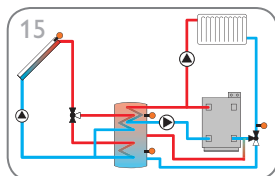

Solar system with store loading in layers, return preheating and backup heating (page 23)

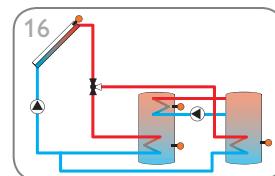

Solar system with store loading in layers and heat exchange (page 24)

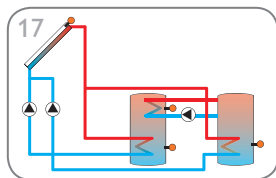

Solar system with 2 stores, valve logic and heat exchange (page 25)

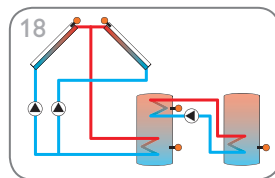

Solar system with east-/west collectors, 2 stores, pump logic and heat exchange (page 26)

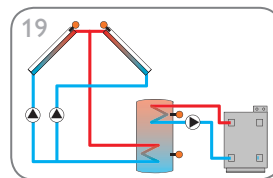

Solar system with east-/west collectors and backup heating (page 27)

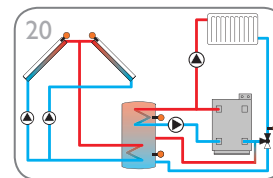

Solar system with east-/west collectors, return preheating and backup heating (page 28)

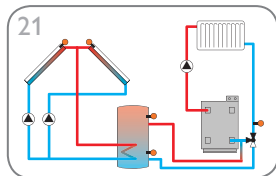

Solar system with east-/west collectors and return preheating (page 29)

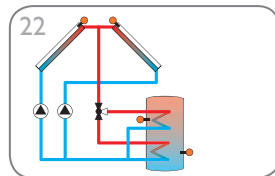

Solar system with east-/west collectors and store loading in layers (page 30)

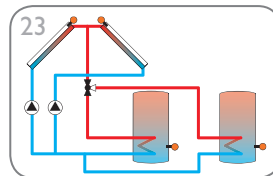

Solar system with east-/west collectors, 2 stores and valve logic (page 31)

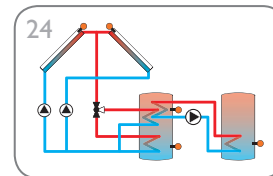

Solar system with east-/west collectors and heat exchange (page 32)

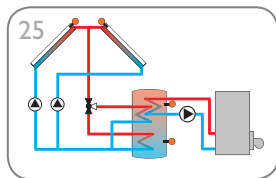

Solar system with east-/west collectors and backup heating (page 33)

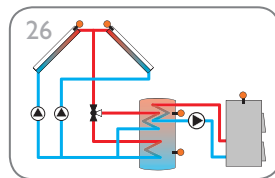

Solar system with east-/west collectors and solid fuel boiler (page 34)

2.6 Systems

System 1: Standard solar system with 1 store

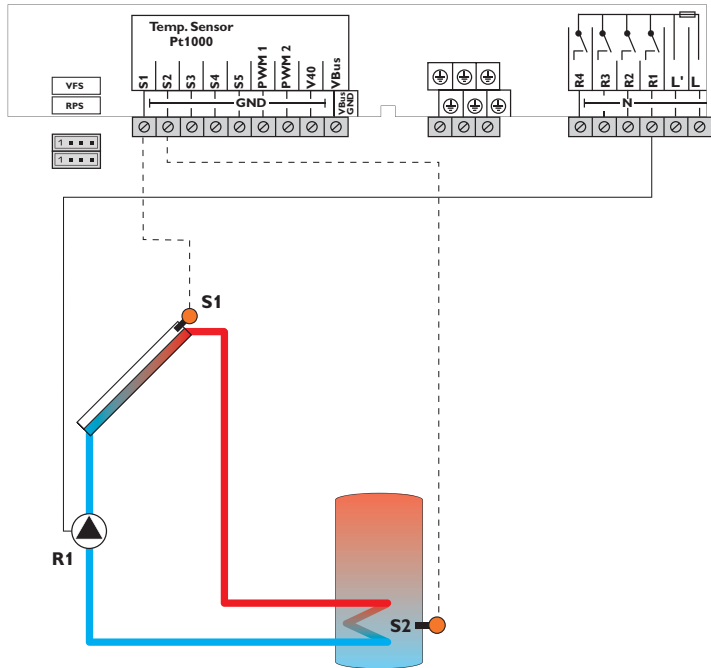

Sensors

S1	Temperature collector	1/GND
S2	Temperature store base	2/GND
S3	Free	3/GND
S4	Free	4/GND
S5	Free	5/GND

Relay

R1	Solar pump	R1/N/PE
R2	Free	R2/N/PE
R3	Free	R3/N/PE
R4	Free	R4/R4

The controller calculates the temperature difference between collector sensor S1 and store sensor S2. If the difference is larger than or identical to the adjusted switch-on temperature difference, the pump (R1) will be switched on and the store will be loaded until the switch-off temperature difference or the maximum store temperature is reached.

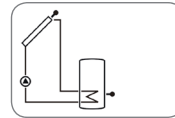

System 2: Solar system with 1 store and heat exchange

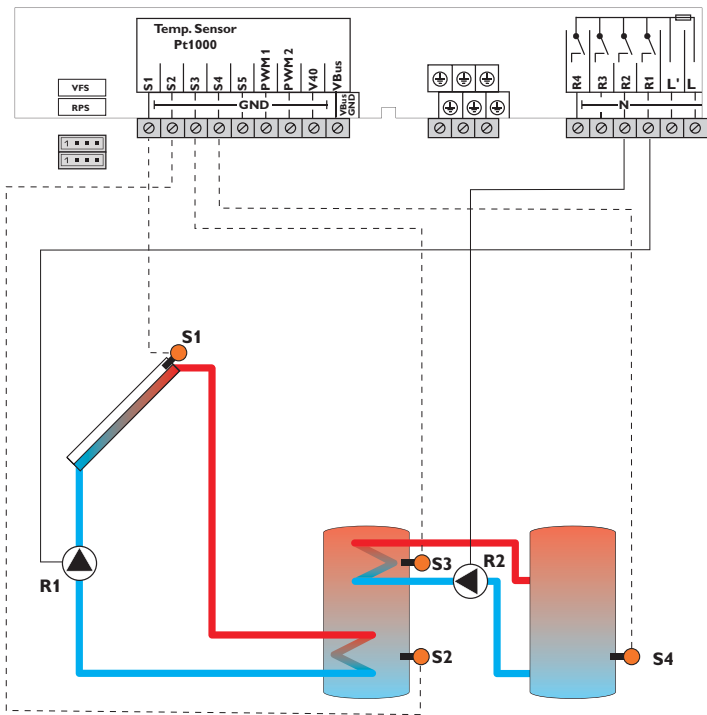

Sensors		Relay		
S1	Temperature collector	1/GND	R1 Solar pump	R1/N/PE
S2	Temperature store base	2/GND	R2 Store loading pump	R2/N/PE
S3	Temperature heat exchange source	3/GND	R3 Free	R3/N/PE
S4	Temperature heat exchange sink	4/GND	R4 Free	R4/N/PE
S5	Free	5/GND		

The controller calculates the temperature difference between collector sensor S1 and store sensor S2. If the difference is larger than or identical to the adjusted switch-on temperature difference, the pump (R1) will be switched on and the store will be loaded until the switch-off temperature difference or the maximum store temperature is reached.

Heat exchange control to an existent store via an additional pump (R2) can be carried out with another temperature differential function (S3 heat source/S4 heat sink).

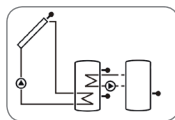

System 3: Solar system with 1 store and backup heating

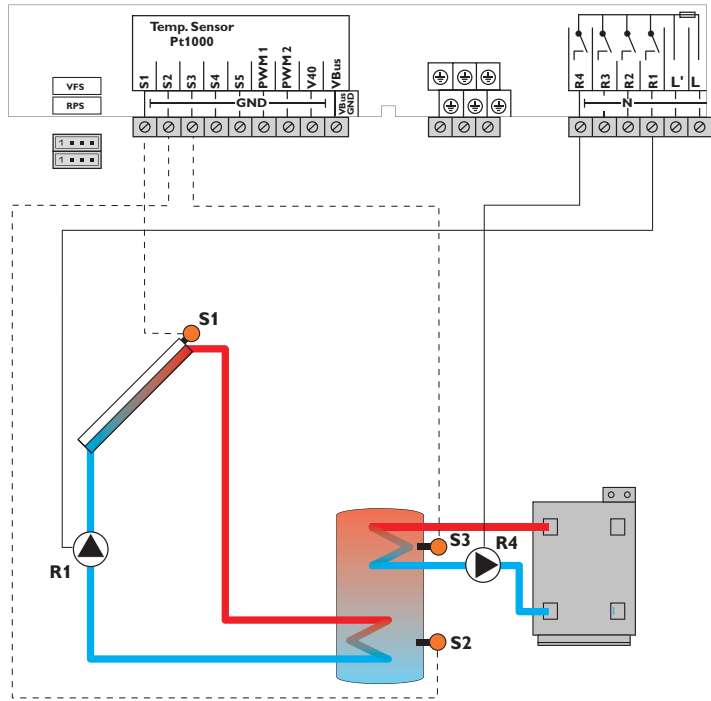

Sensors			Relay		
S1	Temperature collector	1/GND	R1	Solar pump	R1/N/PE
S2	Temperature store base	2/GND	R2	Free	R2/N/PE
S3	Temperature backup heating	3/GND	R3	Free	R3/N/PE
S4	Free	4/GND	R4	Backup heating/Store loading pump	R4/N/PE
S5	Free	5/GND			

The controller calculates the temperature difference between collector sensor S1 and store sensor S2. If the difference is larger than or identical to the adjusted switch-on temperature difference, the pump (R1) will be switched on and the store will be loaded until the switch-off temperature difference or the maximum store temperature is reached.

Backup heating (R4) can be carried out with a thermostat function (S3). If the value at S3 reaches the switch-on temperature for the backup heating, the relay is switched on. If the value exceeds the switch-off temperature for the backup heating, the relay is switched off again.

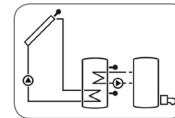

System 4: Solar system with 1 store and store loading in layers

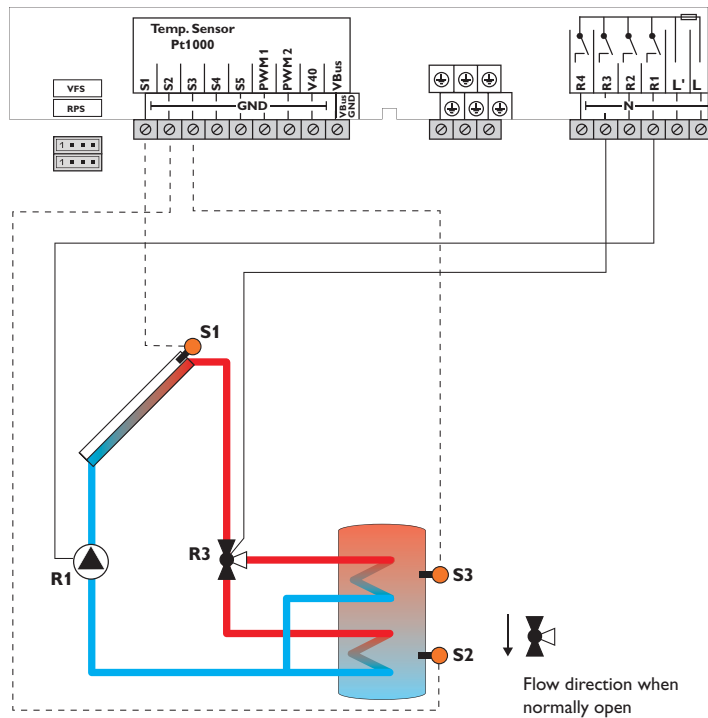

Sensors			Relay		
S1	Temperature collector	1/GND	R1	Solar pump	R1/N/PE
S2	Temperature store base	2/GND	R2	Free	R2/N/PE
S3	Temperature store top	3/GND	R3	Solar valve	R3/N/PE
S4	Free	4/GND	R4	Free	R4/N/PE
S5	Free	5/GND			

The controller compares the temperature at sensor S1 to the temperatures at sensors S2 and S3. If the measured temperature differences are higher than the adjusted switch-on temperature differences, the pump (R1) will be activated and the corresponding store zone will be loaded up to the adjusted store maximum or set temperature respectively via the valve (R3). The priority logic effects prior loading of the upper zone of the store.

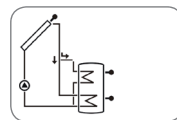

System 5: 2-store solar system with valve logic

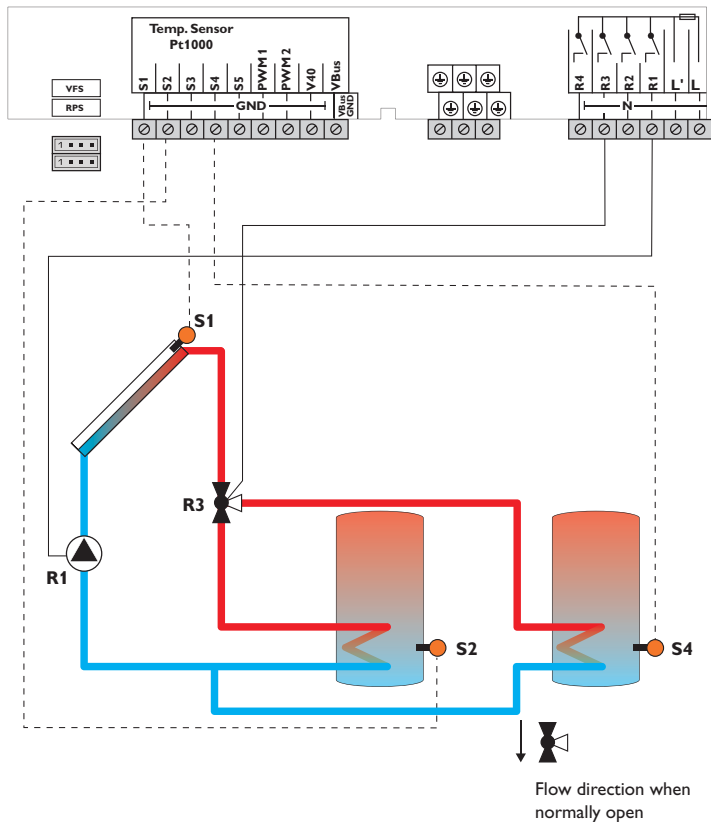

Sensors		
S1	Temperature collector	1/GND
S2	Temperature store 1 base	2/GND
S3	Free	3/GND
S4	Temperature store 2 base	4/GND
S5	Free	5/GND

Relay		
R1	Solar pump	R1/N/PE
R2	Free	R2/N/PE
R3	Solar valve	R3/N/PE
R4	Free	R4/N/PE

The controller compares the temperature at sensor S1 to the temperatures at sensors S2 and S4. If the measured temperature differences are higher than the adjusted switch-on temperature differences, the pump (R1) will be activated and the corresponding store will be loaded up to the adjusted store maximum or set temperature respectively via the valve (R3). The priority logic effects prior loading of store 1.

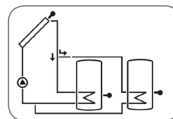

System 6: 2-store solar system with pump logic

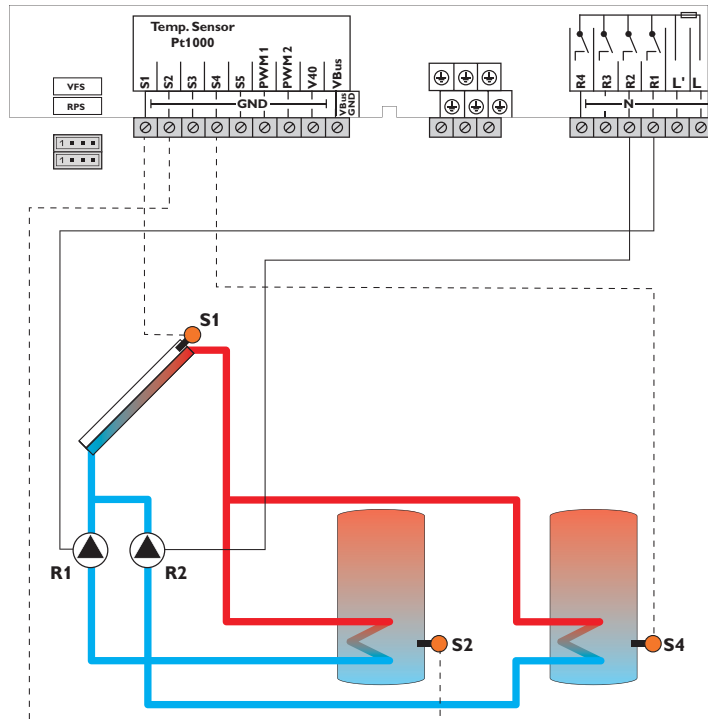

Sensors		Relay	
S1	Temperature collector	1/GND	R1 Solar pump store 1 R1/N/PE
S2	Temperature store 1 base	2/GND	R2 Solar pump store 2 R2/N/PE
S3	Free	3/GND	R3 Free R3/N/PE
S4	Temperature store 2 base	4/GND	R4 Free R4/R4
S5	Free	5/GND	

The controller compares the temperature at sensor S1 to the temperatures at sensors S2 and S4. If the measured temperature differences are higher than the adjusted switch-on temperature differences, the pump (R1 and/or R2) will be activated and the corresponding store will be loaded up to the adjusted store maximum or set temperature respectively at most. The priority logic effects prior loading of store 1.

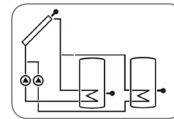

System 7: Solar system with east-/ west collectors

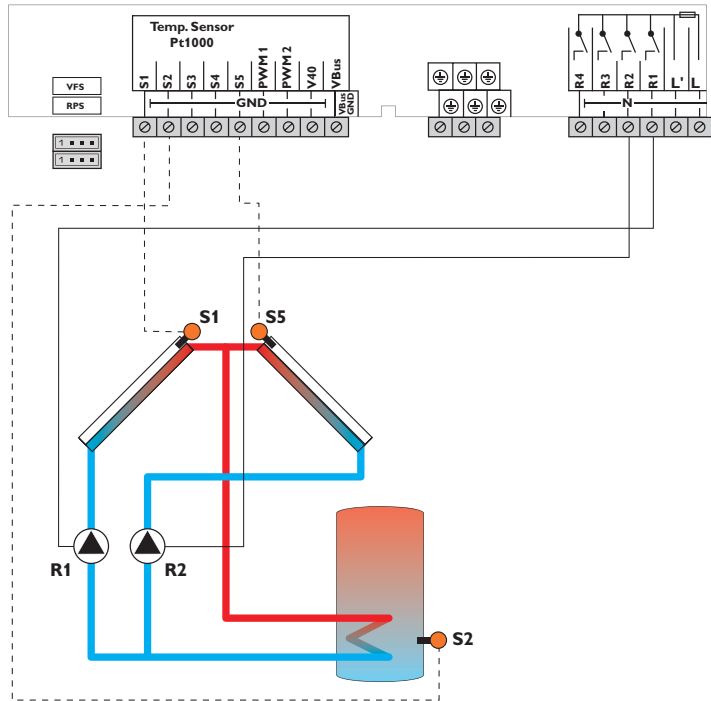

Sensors			Relay		
S1	Temperature collector 1	1/GND	R1	Solar pump collector 1	R1/N/PE
S2	Temperature store base	2/GND	R2	Solar pump collector 2	R2/N/PE
S3	Free	3/GND	R3	Free	R3/N/PE
S4	Free	4/GND	R4	Free	R4/R4
S5	Temperature collector 2	5/GND			

The controller compares the temperatures at the collector sensors S1 and S5 to the store temperature at sensor S2. If one of the measured temperature difference is higher than the adjusted switch-on temperature difference, the corresponding pump (R1 and/or R2) will be switched on, thus loading the store until either the switch-off temperature difference or the store maximum temperature is reached.

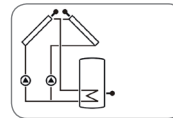

System 8: Solar system with 1 store and backup heating with solid fuel boiler

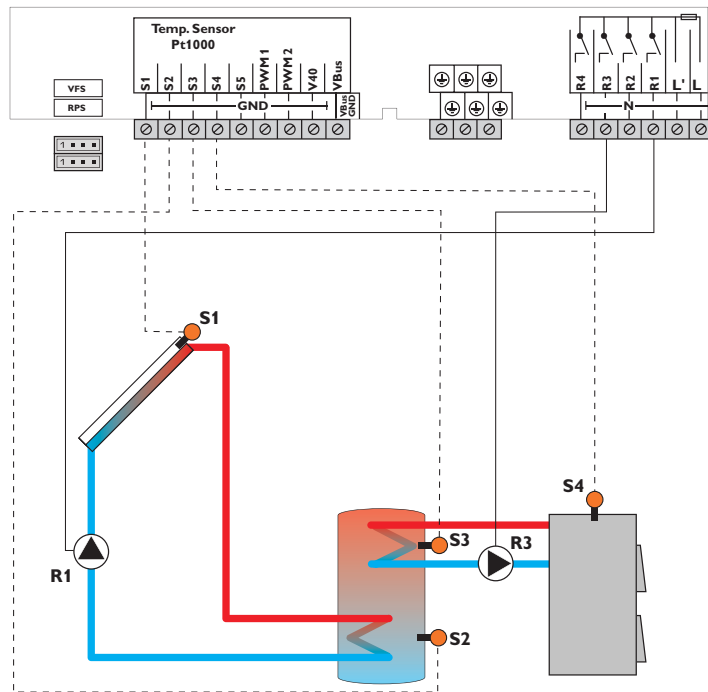

Sensors			Relay		
S1	Temperature collector	1/GND	R1	Solar pump	R1/N/PE
S2	Temperature store base	2/GND	R2	Free	R2/N/PE
S3	Temperature store top	3/GND	R3	Loading pump Solid fuel boiler	R3/N/PE
S4	Temperature solid fuel boiler	4/GND	R4	Free	R4/N/PE
S5	Free	5/GND			

The controller calculates the temperature difference between collector sensor S1 and store sensor S2. If the difference is larger than or identical to the adjusted switch-on temperature difference, the pump (R1) will be switched on and the store will be loaded until the switch-off temperature difference or the maximum store temperature is reached.

With another temperature differential function (S4 heat source/S3 heat sink), backup heating of the store with a solid fuel boiler can be carried out via another pump (R3).

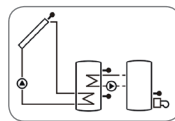

System 9: Solar system with 1 store and return preheating

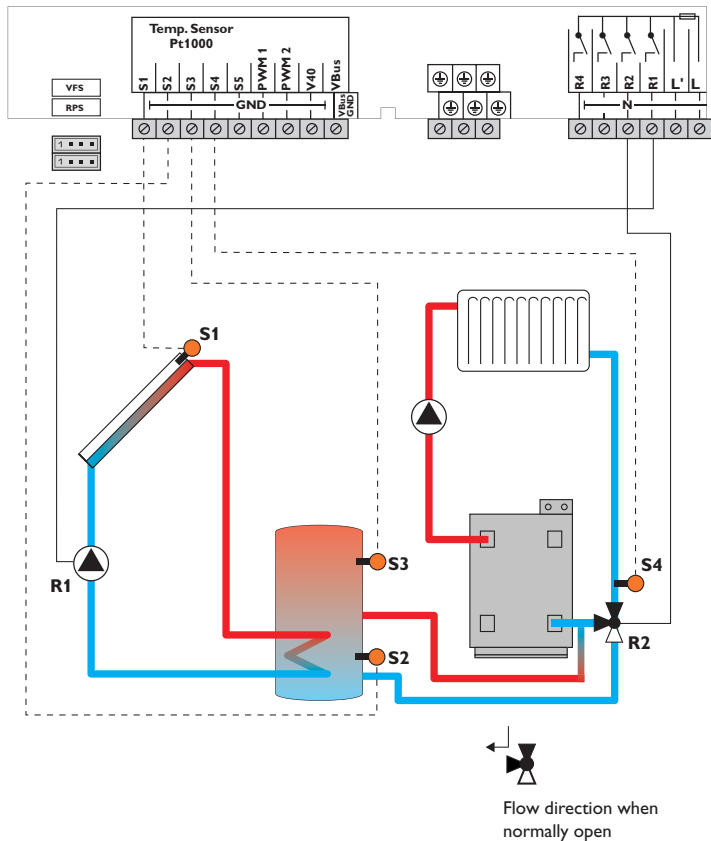

Sensors			Relay		
S1	Temperature collector	1/GND	R1	Solar pump	R1/N/PE
S2	Temperature store base	2/GND	R2	Valve return preheating	R2/N/PE
S3	Temperature store return preheating	3/GND	R3	Free	R3/N/PE
S4	Temperature heating return	4/GND	R4	Free	R4/N/PE
S5	Free	5/GND			

The controller calculates the temperature difference between collector sensor S1 and store sensor S2. If the difference is larger than or identical to the adjusted switch-on temperature difference, the pump (R1) will be switched on and the store will be loaded until the switch-off temperature difference or the maximum store temperature is reached.

With another temperature differential function (S3 heat source/S4 heat sink) return preheating (heating circuit backup) is possible via another valve (R2).

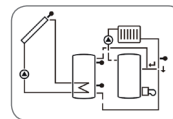

System 10: Solar system with 1 store, return preheating and thermostatic backup heating

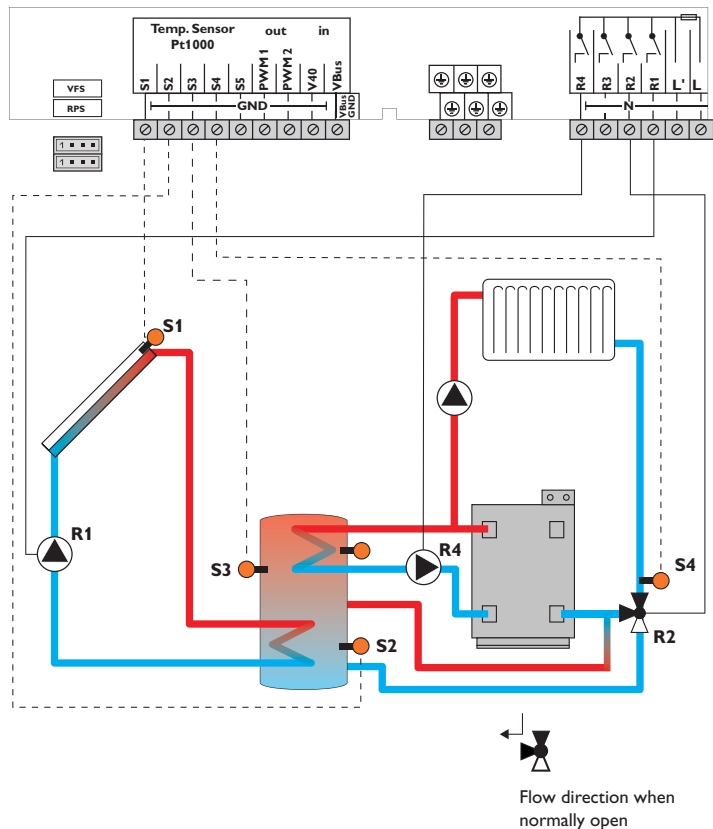

Sensors		Relay		
S1	Temperature collector	1/GND	R1 Solar pump	R1/N/PE
S2	Temperature store base	2/GND	R2 Valve return preheating	R2/N/PE
S3	Temperature store return preheating/ Temperature backup heating	3/GND	R3 Free	R3/N/PE
S4	Temperature heating return	4/GND	R4 Backup heating/Store loading pump	R4/N/PE
S5	Free	5/GND		

The controller calculates the temperature difference between collector sensor S1 and store sensor S2. If the difference is larger than or identical to the adjusted switch-on temperature difference, the pump (R1) will be switched on and the store will be loaded until the switch-off temperature difference or the maximum store temperature is reached.

Backup heating (R4) can be carried out with a thermostat function (S3). If the value at S3 reaches the switch-on temperature for the backup heating, the relay is switched on. If the value exceeds the switch-off temperature for the backup heating, the relay is switched off again.

With another temperature differential function (S3 heat source/S4 heat sink) return preheating (heating circuit backup) is possible via another valve (R2).

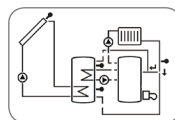

System 11: Solar system with store loading in layers and heat exchange control

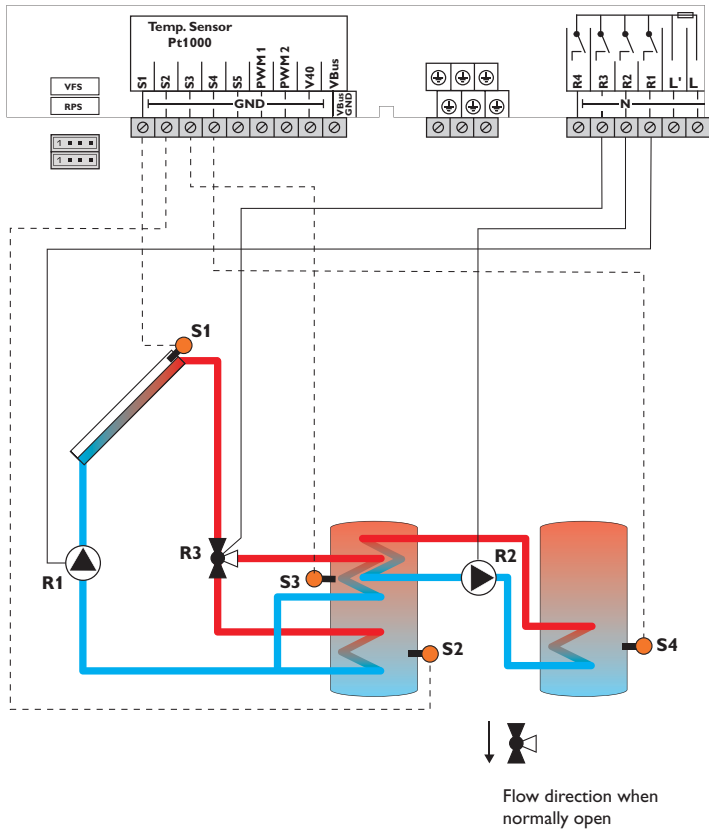

Sensors		
S1	Temperature collector	1/GND
S2	Temperature store base	2/GND
S3	Temperature store top/ Temperature heat exchange source	3/GND
S4	Temperature heat exchange sink	4/GND
S5	Free	5/GND

Relay		
R1	Solar pump	R1/N/PE
R2	Store loading pump	R2/N/PE
R3	Solar valve	R3/N/PE
R4	Free	R4/N/PE

The controller compares the temperature at sensor S1 to the temperatures at sensors S2 and S3. If the measured temperature differences are higher than the adjusted switch-on temperature differences, the pump (R1) will be activated and the corresponding store zone will be loaded up to the adjusted store maximum or set temperature respectively via the valve (R3). The priority logic effects prior loading of the upper zone of the store.

Heat exchange control to an existent store via an additional pump (R2) can be carried out with another temperature differential function (S3 heat source/S4 heat sink).

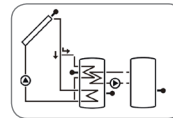

System 12: Solar system with store loading in layers and thermostatic backup heating

en
Installation

Operation and function

Commissioning

Indications, functions and options

Messages

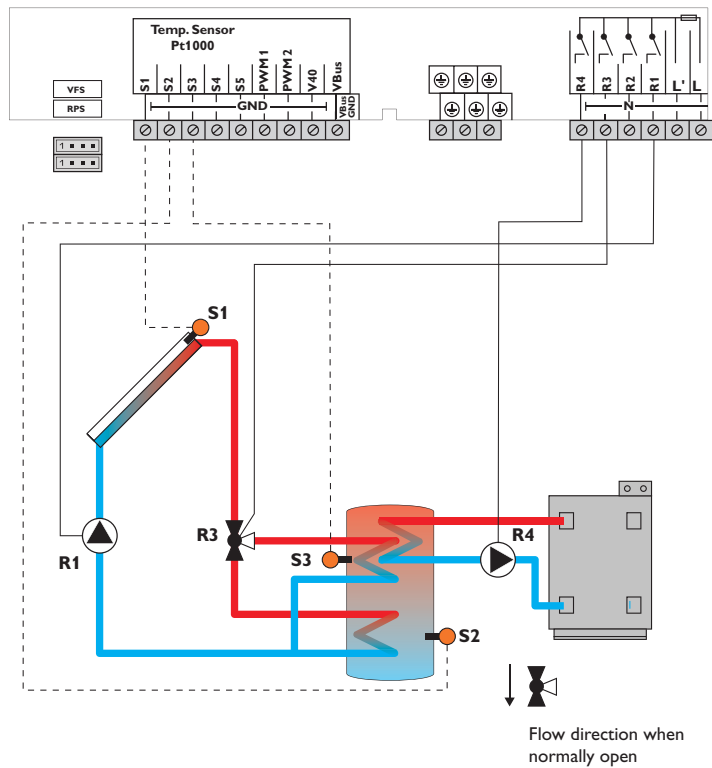

Sensors		
S1	Temperature collector	1/GND
S2	Temperature store base	2/GND
S3	Temperature store return preheating/ Temperature backup heating	3/GND
S4	Free	4/GND
S5	Free	5/GND

Relay		
R1	Solar pump	R1/N/PE
R2	Free	R2/N/PE
R3	Solar valve	R3/N/PE
R4	Backup heating/Store loading pump	R4/N/PE

The controller compares the temperature at sensor S1 to the temperatures at sensors S2 and S3. If the measured temperature differences are higher than the adjusted switch-on temperature differences, the pump (R1) will be activated and the corresponding store zone will be loaded up to the adjusted store maximum or set temperature respectively via the valve (R3). The priority logic effects prior loading of the upper zone of the store.

Backup heating (R4) can be carried out with a thermostat function (S3). If the value at S3 reaches the switch-on temperature for the backup heating, the relay is switched on. If the value exceeds the switch-off temperature for the backup heating, the relay is switched off again.

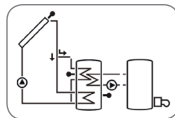

System 13: Solar system with store loading in layers and backup heating with solid fuel boiler

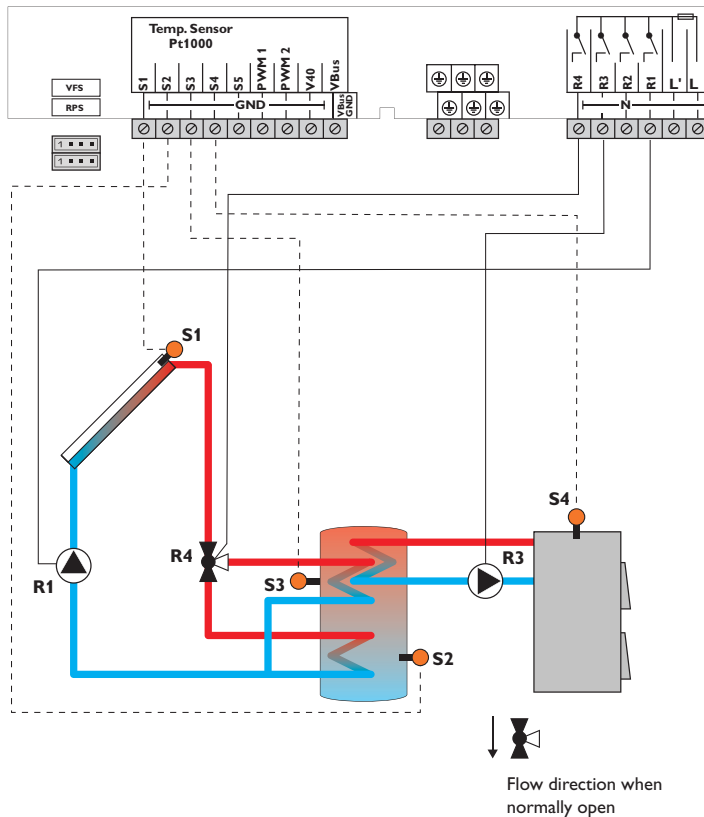

Sensors		
S1	Temperature collector	1/GND
S2	Temperature store base	2/GND
S3	Temperature store top/ Temperature store - solid fuel boiler	3/GND
S4	Temperature solid fuel boiler	4/GND
S5	Free	5/GND

Relay		
R1	Solar pump	R1/N/PE
R2	Free	R2/N/PE
R3	Loading pump Solid fuel boiler	R3/N/PE
R4	Solar valve	R4/N/PE

The controller compares the temperature at sensor S1 to the temperatures at sensors S2 and S3. If the measured temperature differences are higher than the adjusted switch-on temperature differences, the pump (R1) will be activated and the corresponding store zone will be loaded up to the adjusted store maximum or set temperature respectively via the valve (R4). The priority logic effects prior loading of the upper zone of the store. With another temperature differential function (S4 heat source/S3 heat sink), backup heating of the store with a solid fuel boiler can be carried out via another pump (R3).

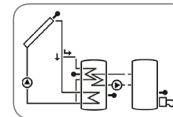

System 14: Solar system with store loading in layers and return preheating

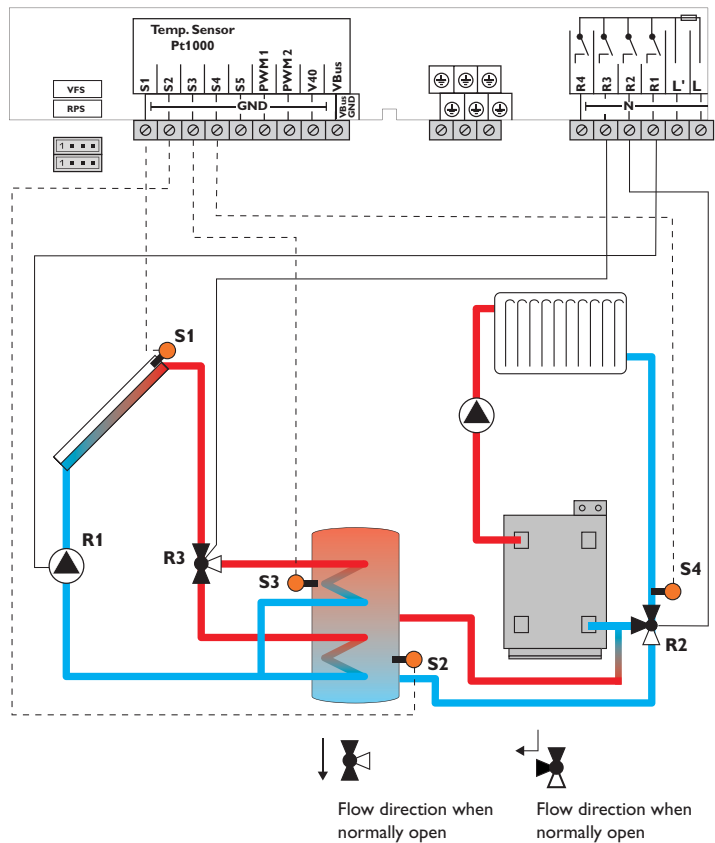

Sensors		Relay		
S1	Temperature collector	1/GND	R1 Solar pump	R1/N/PE
S2	Temperature store base	2/GND	R2 Valve return preheating	R2/N/PE
S3	Temperature store top/ Temperature store return preheating	3/GND	R3 Solar valve	R3/N/PE
S4	Temperature heating return	4/GND	R4 Free	R4/N/PE
S5	Free	5/GND		

The controller compares the temperature at sensor S1 to the temperatures at sensors S2 and S3. If the measured temperature differences are higher than the adjusted switch-on temperature differences, the pump (R1) will be activated and the corresponding store zone will be loaded up to the adjusted store maximum or set temperature respectively via the valve (R3). The priority logic effects prior loading of the upper zone of the store.

With another temperature differential function (S5 heat source/S4 heat sink) return preheating (heating circuit backup) is possible via another valve (R2).

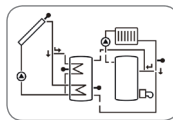

System 15: Solar system with store loading in layers, return preheating and backup heating

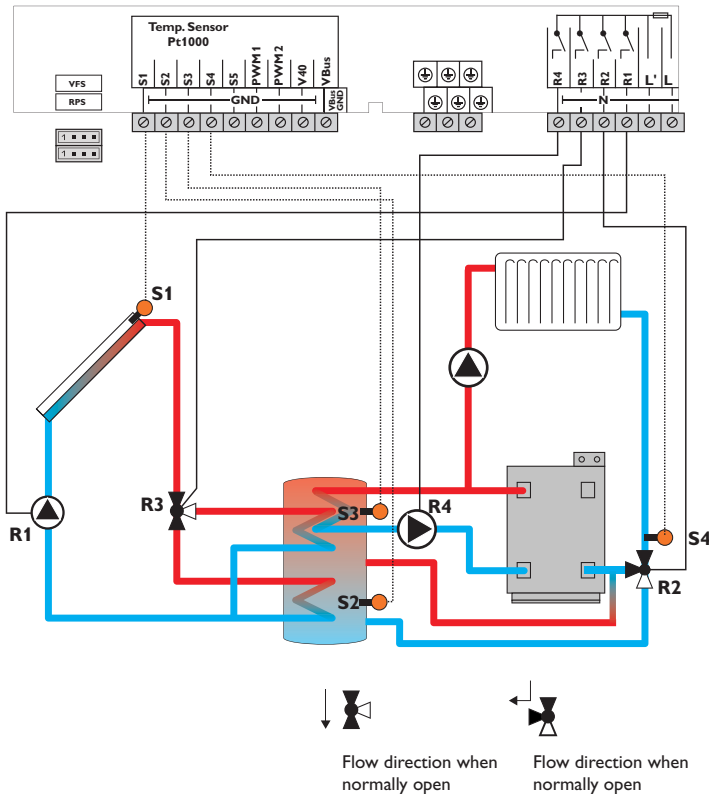

Sensors		
S1	Temperature collector	1/GND
S2	Temperature store base	2/GND
S3	Temperature store top/ Temperature store return preheating	3/GND
S4	Temperature return	4/GND
S5	Free	5/GND

Relay		
R1	Solar pump store	R1/N/PE
R2	Valve	R2/N/PE
R3	Solar valve	R3/N/PE
R4	Backup heating/Store loading pump	R4/N/PE

The controller compares the temperature at sensor S1 to the temperatures at sensors S2 and S3. If the measured temperature differences are higher than the adjusted switch-on temperature differences, the pump (R1) will be activated and the corresponding store zone will be loaded up to the adjusted store maximum or set temperature respectively via the valve (R3).

The priority logic effects prior loading of the upper zone of the store. With another temperature differential function (S3 heat source/S4 heat sink) return preheating (heating circuit backup) is possible via another valve (R2). Backup heating (R4) can be carried out with a thermostat function (S3). If the value at S3 reaches the switch-on temperature for the backup heating, the relay is switched on. If the value exceeds the switch-off temperature for the backup heating, the relay is switched off again.

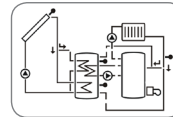

System 16: 2-store solar system with valve logic and heat exchange control

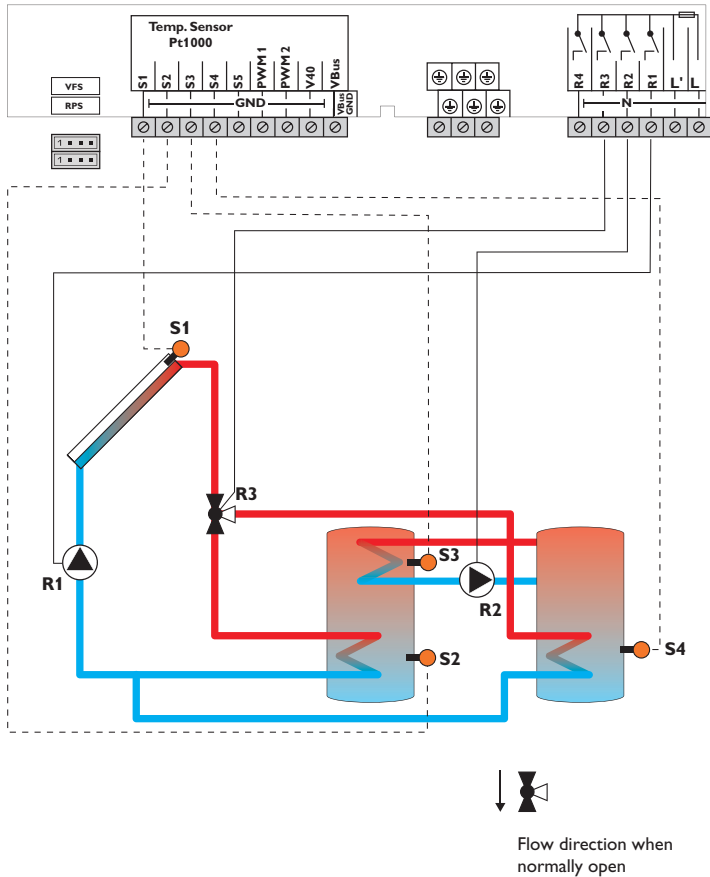

Sensors		Relay		
S1	Temperature collector	1/GND	R1 Solar pump	R1/N/PE
S2	Temperature store base	2/GND	R2 Store loading pump	R2/N/PE
S3	Temperature heat exchange source	3/GND	R3 Solar valve	R3/N/PE
S4	Temperature store 2 base and heat exchange sink	4/GND	R4 Free	R4/N/PE
S5	Free	5/GND		

The controller compares the temperature at sensor S1 to the temperatures at sensors S2 and S4. If the measured temperature differences are higher than the adjusted switch-on temperature differences, the pump (R1) will be activated and the corresponding store will be loaded up to the adjusted store maximum or set temperature respectively via the valve (R3). The priority logic effects prior loading of store 1.

Heat exchange control to an existent store via an additional pump (R2) can be carried out with another temperature differential function (S3 heat source/S4 heat sink).

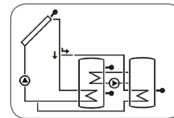

Flow direction when normally open

System 17: 2-store solar system with pump logic and heat exchange control

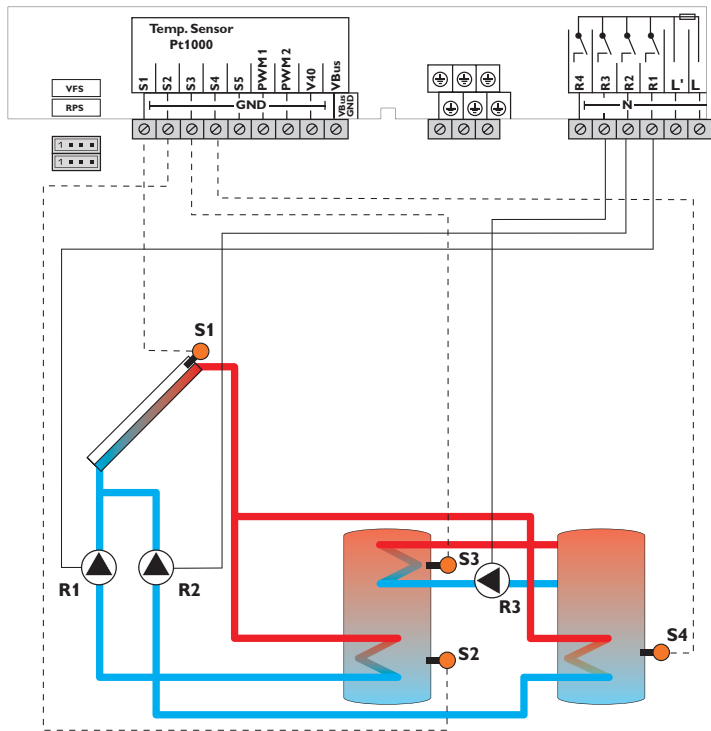

Sensors		
S1	Temperature collector	1/GND
S2	Temperature store 1 base	2/GND
S3	Temperature heat exchange source	3/GND
S4	Temperature store 2 base and heat exchange sink	4/GND
S5	Free	5/GND

Relay		
R1	Solar pump store 1	R1/N/PE
R2	Solar pump store 2	R2/N/PE
R3	Store loading pump	R3/N/PE
R4	Free	R4/R4

The controller compares the temperature at sensor S1 to the temperatures at sensors S2 and S4. If the measured temperature differences are higher than the adjusted switch-on temperature differences, the pump (R1 and/or R2) will be activated and the corresponding store will be loaded up to the adjusted store maximum or set temperature respectively at most. The priority logic effects prior loading of store 1.

Heat exchange control to an existent store via an additional pump (R3) can be carried out with another temperature differential function (S3 heat source/S4 heat sink).

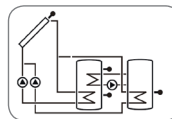

System 18: Solar system with east-/west collectors and heat exchange control

en

Installation

Operation and function

Commissioning

Indications, functions and options

Messages

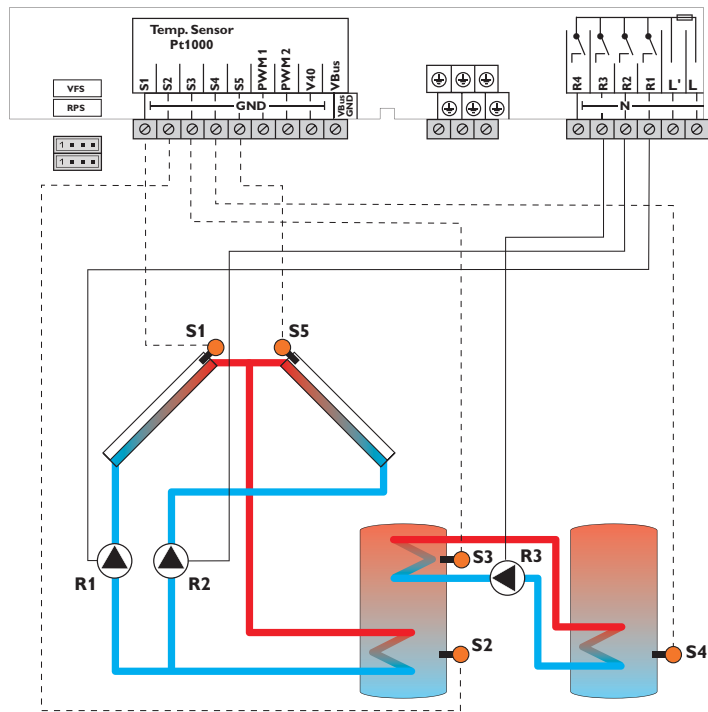

Sensors		Relay		
S1	Temperature collector 1	1/GND	R1 Solar pump collector 1	R1/N/PE
S2	Temperature store base	2/GND	R2 Solar pump collector 2	R2/N/PE
S3	Temperature heat exchange source	3/GND	R3 Store loading pump	R3/N/PE
S4	Temperature heat exchange sink	4/GND	R4 Free	R4/N/PE
S5	Temperature collector 2	5/GND		

The controller compares the temperatures at the collector sensors S1 and S5 to the store temperature at sensor S2. If one of the measured temperature difference is higher than the adjusted switch-on temperature difference, the corresponding pump (R1 and/or R2) will be switched on, thus loading the store until either the switch-off temperature difference or the store maximum temperature is reached. Heat exchange control to an existent store via an additional pump (R3) can be carried out with another temperature differential function (S3 heat source/S4 heat sink).

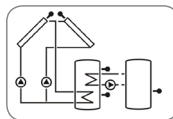

System 19: Solar system with east-/west collectors and thermostatic backup heating

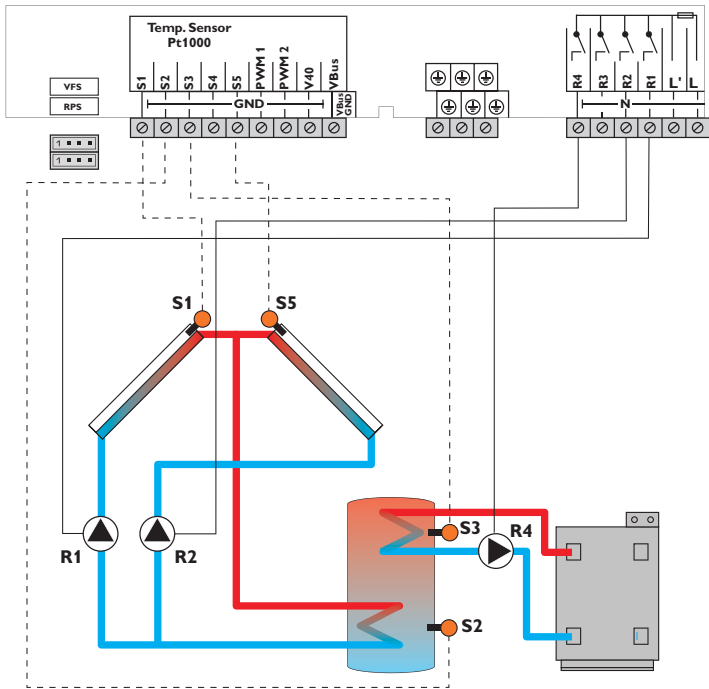

Sensors		
S1	Temperature collector 1	1/GND
S2	Temperature store base	2/GND
S3	Temperature backup heating	3/GND
S4	Free	4/GND
S5	Temperature collector 2	5/GND

Relay		
R1	Solar pump collector 1	R1/N/PE
R2	Solar pump collector 2	R2/N/PE
R3	Free	R3/N/PE
R4	Backup heating/Store loading pump	R4/N/PE

The controller compares the temperatures at the collector sensors S1 and S5 to the store temperature at sensor S2. If one of the measured temperature difference is higher than the adjusted switch-on temperature difference, the corresponding pump (R1 and/or R2) will be switched on, thus loading the store until either the switch-off temperature difference or the store maximum temperature is reached. Backup heating (R4) can be carried out with a thermostat function (S3). If the value at S3 reaches the switch-on temperature for the backup heating, the relay is switched on. If the value exceeds the switch-off temperature for the backup heating, the relay is switched off again.

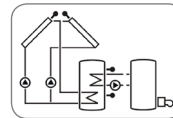

System 20: Solar system with east-/west collectors, return preheating and backup heating

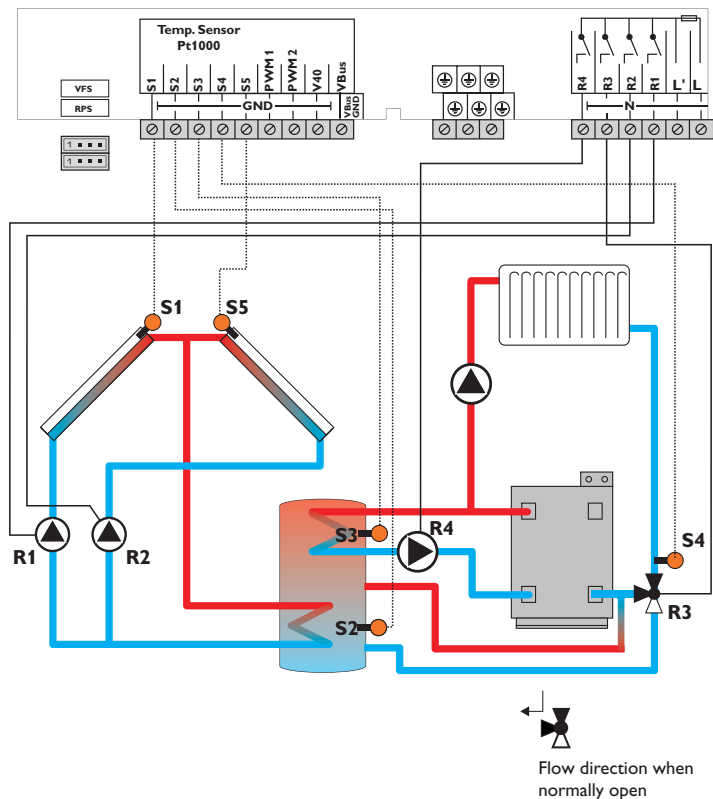

Sensors	
S1	Temperature collector 1 1/GND
S2	Temperature store base 2/GND
S3	Temperature store top/ Temperature store return preheating 3/GND
S4	Temperature heating return 4/GND
S5	Temperature collector 2 5/GND

Relay	
R1	Solar pump collector 1 R1/N/PE
R2	Solar pump collector 2 R2/N/PE
R3	Return preheating R3/N/PE
R4	Backup heating/Store loading pump R4/N/PE

The controller compares the temperatures at the collector sensors S1 and S5 to the store temperature at sensor S2. If one of the measured temperature difference is higher than the adjusted switch-on temperature difference, the corresponding pump (R1 and/or R2) will be switched on, thus loading the store until either the switch-off temperature difference or the store maximum temperature is reached. With another temperature differential function (S3 heat source/S4 heat sink) return preheating (heating circuit backup) is possible via another valve (R3). Backup heating (R4) can be carried out with a thermostat function (S3). If the value at S3 reaches the switch-on temperature for the backup heating, the relay is switched on. If the value exceeds the switch-off temperature for the backup heating, the relay is switched off again.

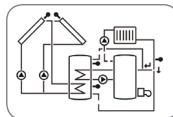

System 21: Solar system with east-/west collectors and return preheating

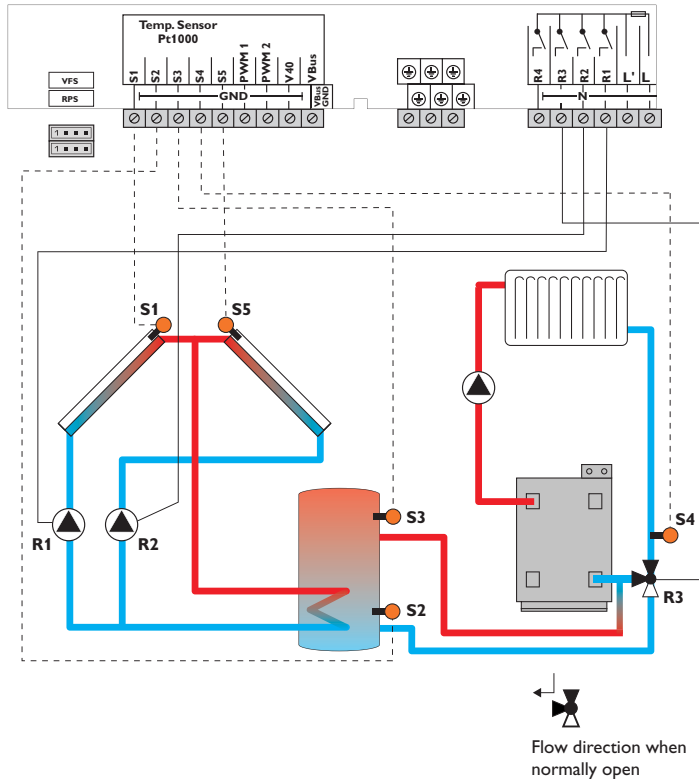

Sensors			Relay		
S1	Temperature collector 1	1/GND	R1	Solar pump collector 1	R1/N/PE
S2	Temperature store base	2/GND	R2	Solar pump collector 2	R2/N/PE
S3	Temperature store return preheating	3/GND	R3	Valve return preheating	R3/N/PE
S4	Temperature heating return	4/GND	R4	Free	R4/N/PE
S5	Temperature collector 2	5/GND			

The controller compares the temperatures at the collector sensors S1 and S5 to the store temperature at sensor S2. If one of the measured temperature difference is higher than the adjusted switch-on temperature difference, the corresponding pump (R1 and/or R2) will be switched on, thus loading the store until either the switch-off temperature difference or the store maximum temperature is reached. With another temperature differential function (S3 heat source/S4 heat sink) return preheating (heating circuit backup) is possible via another valve (R3).

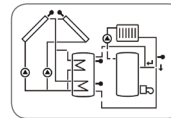

System 22: Solar system with store loading in layers and east-/west collectors

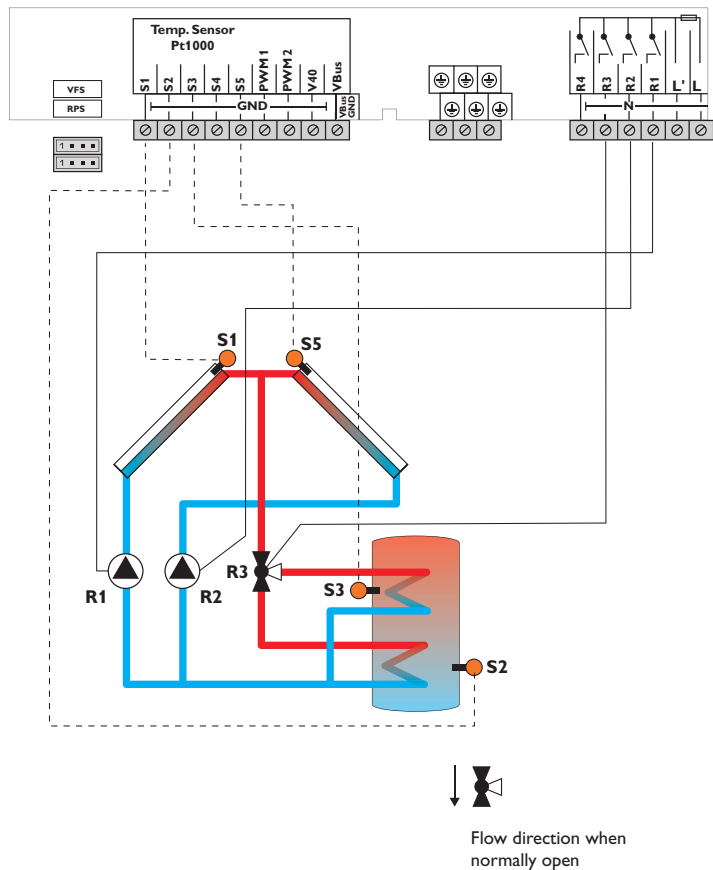

Sensors			Relay		
S1	Temperature collector 1	1/GND	R1	Solar pump collector 1	R1/N/PE
S2	Temperature store base	2/GND	R2	Solar pump collector 2	R2/N/PE
S3	Temperature store top	3/GND	R3	Solar valve	R3/N/PE
S4	Free	4/GND	R4	Free	R4/N/PE
S5	Temperature collector 2	5/GND			

The controller compares the temperatures at the collector sensors S1 and S5 to the store temperature at sensors S2 and S3. If one of the measured temperature differences is higher than the adjusted switch-on temperature difference, the corresponding pump (R1 and/or R2) will be activated and the corresponding store zone will be loaded up to the adjusted store maximum or set temperature respectively via the valve (R3). The priority logic effects prior loading of the upper zone of the store.

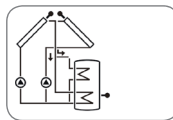

System 23: Solar system with east-/west collectors and 2 stores (valve logic)

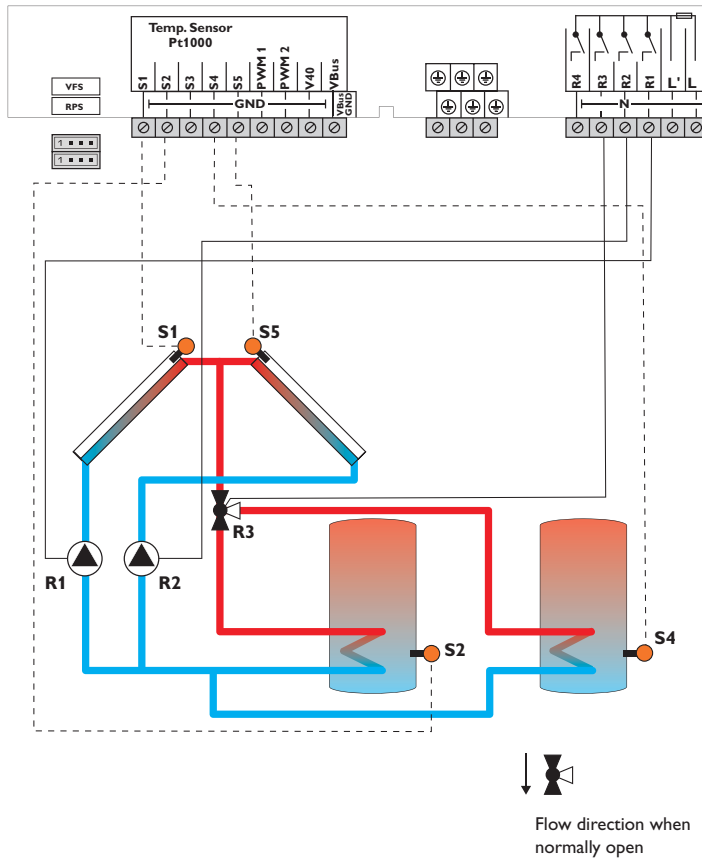

Sensors			Relay		
S1	Temperature collector 1	1/GND	R1	Solar pump collector 1	R1/N/PE
S2	Temperature store 1	2/GND	R2	Solar pump collector 2	R2/N/PE
S3	Free	3/GND	R3	Solar valve	R3/N/PE
S4	Temperature store 2	4/GND	R4	Free	R4/R4
S5	Temperature collector 2	5/GND			

The controller compares the temperatures at the collector sensors S1 and S5 to the store temperature at sensors S2 and S3. If one of the measured temperature differences is higher than the adjusted switch-on temperature differences, the corresponding pump (R1 and/or R2) or both pumps will be activated and the corresponding store will be loaded up to the adjusted maximum temperature via the valve (R3). The priority logic effects prior loading of store 1.

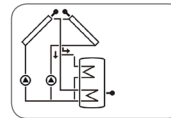

Arrangement 24: Solar system with east-/west collectors, store loading in layers and heat exchange

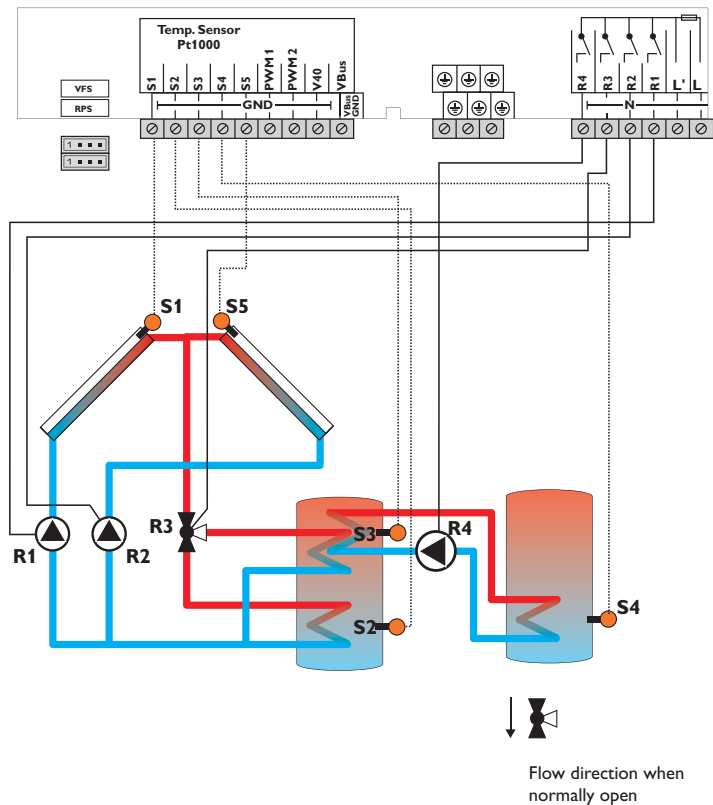

Sensors	
S1	Temperature collector 1 1/GND
S2	Temperature store base 2/GND
S3	Temperature store top/Heat exchange source
S4	Temperature heat exchange sink
S5	Temperature collector 2 5/GND

Relay	
R1	Solar pump collector 1 R1/N/PE
R2	Solar pump collector 2 R2/N/PE
R3	Solar valve R3/N/PE
R4	Heat exchange pump R4/R4

The controller compares the temperatures at the collector sensors S1 and S5 to the store temperature at sensors S2 and S3. If one of the measured temperature differences is higher than the adjusted switch-on temperature difference, the corresponding pump (R1 and/or R2) will be activated and the corresponding store zone will be loaded up to the adjusted store maximum or set temperature respectively via the valve (R3). The priority logic effects prior loading of the upper zone of the store. Heat exchange control to an existent store via an additional pump (R4) can be carried out with another temperature differential function (S3 heat source/S4 heat sink).

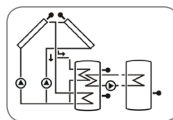

Flow direction when normally open

Arrangement 25: Solar system with east-/west collectors, store loading in layers and thermostatic backup heating

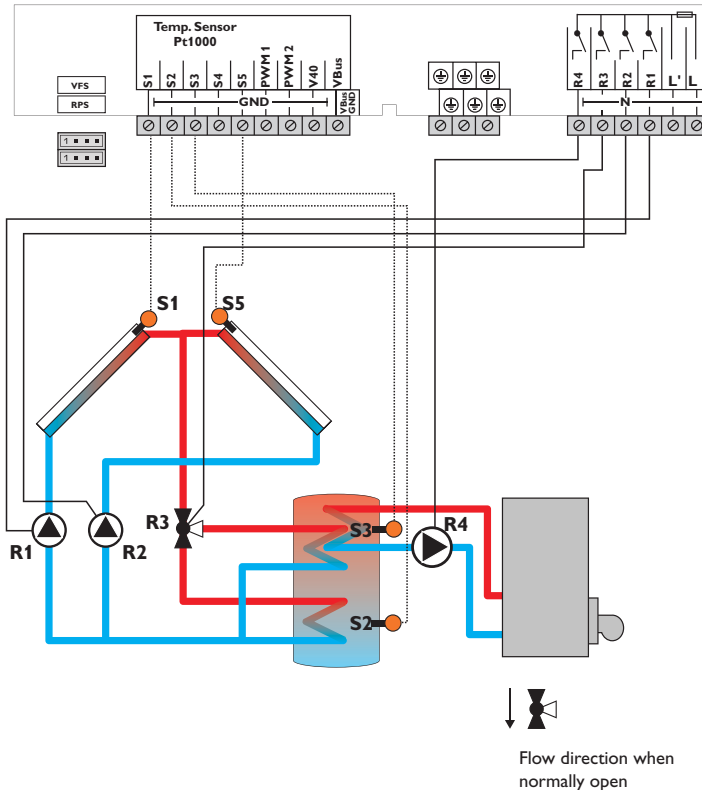

Sensors		
S1	Temperature collector 1	1/GND
S2	Temperature store base	2/GND
S3	Temperature store top	3/GND
S4	Free	4/GND
S5	Temperature collector 2	5/GND

Relay		
R1	Solar pump collector 1	R1/N/PE
R2	Solar pump collector 2	R2/N/PE
R3	Solar valve	R3/N/PE
R4	Backup heating/Store loading pump	R4/R4

The controller compares the temperatures at the collector sensors S1 and S5 to the store temperature at sensors S2 and S3. If one of the measured temperature differences is higher than the adjusted switch-on temperature differences, the corresponding pump (R1, R2) or both pumps will be activated and the corresponding store zone will be loaded up to the adjusted store maximum via the valve (R3). The priority logic effects prior loading of the upper zone of the store. DHW backup heating (R4) can be carried out with a thermostat function (S3).

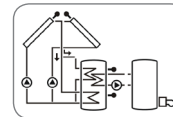

Arrangement 26: Solar system with east-/west collectors, store loading in layers and backup heating with solid fuel boiler

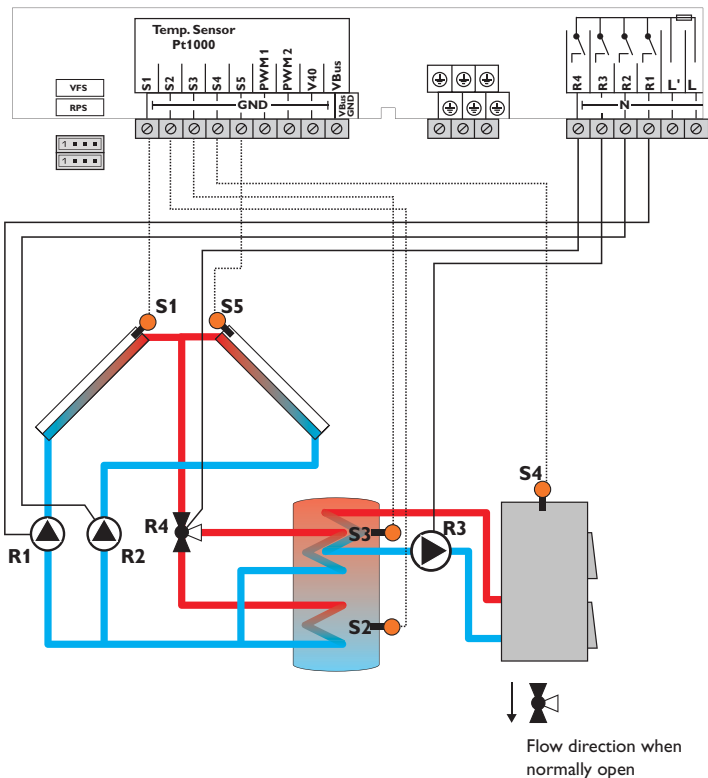

Sensors		Relay		
S1	Temperature collector 1	1/GND	R1 Solar pump collector 1	R1/N/PE
S2	Temperature store base	2/GND	R2 Solar pump collector 2	R2/N/PE
S3	Temperature store top	3/GND	R3 Loading pump Solid fuel boiler	R3/N/PE
S4	Temperature solid fuel boiler	4/GND	R4 Solar valve	R4/R4
S5	Temperature collector 2	5/GND		

The controller compares the temperatures at the collector sensors S1 and S5 to the store temperature at sensors S2 and S3. If one of the measured temperature differences is higher than the adjusted switch-on temperature difference, the corresponding pump (R1 and/or R2) will be activated and the corresponding store zone will be loaded up to the adjusted store maximum or set temperature respectively via the valve (R4). The priority logic effects prior loading of the upper zone of the store.

With another temperature differential function (S4 heat source/S3 heat sink), backup heating of the store with a solid fuel boiler can be carried out via another pump (R3).

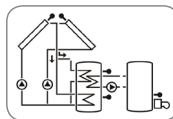

Electrical connection of a high-efficiency pump (HE pump)

Speed control of a HE pump is possible via a PWM signal. The pump has to be connected to the relay (power supply) as well as to one of the PWM outputs 1/2 of the controller. In the PUMP adjustment channel, one of the PWM control types as well as a relay have to be selected (see page 59).

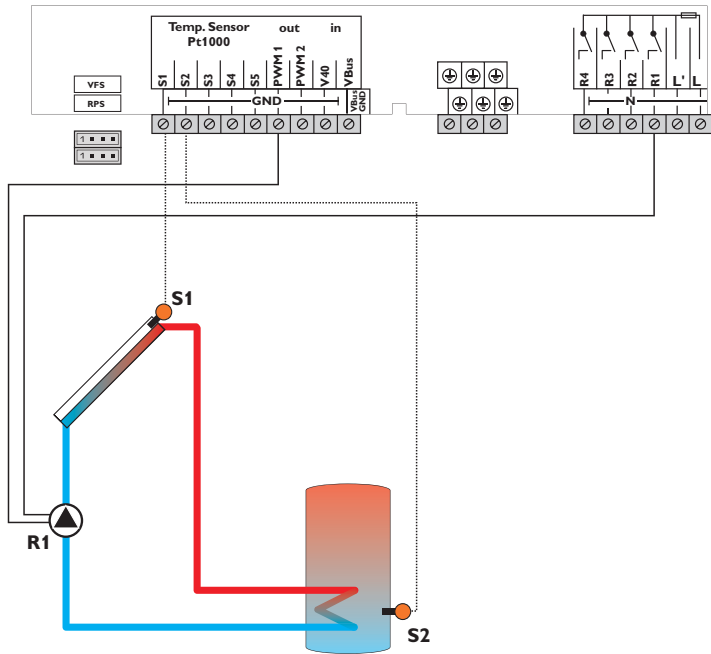

Note:

For more information about loading logic, see page 59.

3 Operation and function

3.1 Buttons

The controller is operated via the 7 buttons next to the display. They have the following functions:

Button 1 - scrolling upwards

Button 3 - scrolling downwards

Button 2 - increasing adjustment values

Button 4 - reducing adjustment values

Button 5 - confirming

Button 6 - menu button for changing between the status and the menu level

Button 7 - escape button for changing into the previous menu

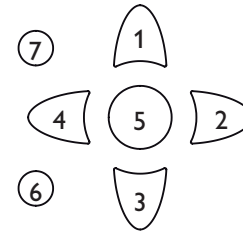

3.2 Menu structure

Status level	Menu level	Adjustment level
TCOL	ARR	DT O
TCOL2	LOAD	DT F
TSTB	COL	DT S
TSTT	...	S SET
...		S MAX
		SMAXS
		...

The menu structure of the controller consists of 3 levels: the status level, the menu level and the adjustment level.

The status level consists of different display channels which indicate display values and messages.

The menu level consists of several menu items, each of which consists of sub-menus and adjustment channels. Each of these menu items represents a function or option which can be selected. If a function or option is selected, the controller changes to the adjustment level in which the corresponding parameters of the function or option are available.

In order to activate or deactivate a function, it must be selected in the menu level. The display changes to the adjustment menu in which all adjustments required can be carried out.

During normal operation of the controller, the display is in the status level.

Menu level

If it is possible to jump into a menu, PUSH is indicated below the menu item. Use button (5) to access the menu. In order to leave the menu, press button (7).

If an option is deactivated, it will appear in the menu level with the addition OFF.



Note:

Some of the menu items depend on the selected system and the adjusted options. Therefore, they are only displayed if they are available.



Note:

The abstract from the menu structure is for information on the structure of the controller menu and is therefore not complete.

3.3 Selecting menu points and adjusting values

During normal operation of the controller, the display is in the status level.

In order to leave the status level and access the menu level, press button (6).

The display indicates the level with the selectable menus. In order to change the parameters of a menu item, select the menu item and press button (5). The display changes to the adjustment level. The adjustment channels are characterised by the indication **SET**.

- Select the desired channel by pressing the buttons (1) and (3).
- Confirm the selection with button (5), **SET** flashes (adjustment mode).
- Adjust the value, the function or the option using the buttons (2) and (4).
- Confirm the selection with button (5), **SET** permanently appears, the adjustment has been saved.

If no button has been pressed within a couple of minutes, the adjustment is cancelled and the previous value is retained.

4 System-Monitoring-Display

System-Monitoring-Display

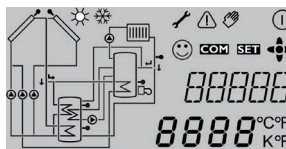

The System-Monitoring-Display consists of 3 blocks: channel display, tool bar and system screen.

Channel display



The channel display consists of 2 lines. The upper display line is an alphanumeric 16-segment display. In this line, mainly channel names and menu items are displayed. In the lower 7-segment display, values are displayed.

Tool bar



The additional symbols in the tool bar indicate the current system state.

4.1 System screen

The system selected is indicated in the System-Monitoring-Display. It consists of several system component symbols which are – depending on the current status of the system – either flashing, permanently shown or not indicated.

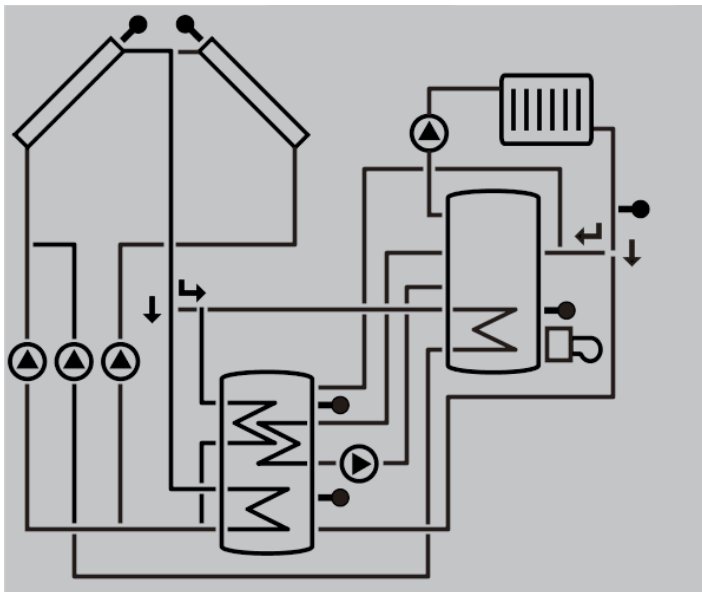

Collectors
with collector sensor

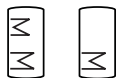

Store 1 and 2 with
heat exchanger



3-port valves
Only the flow direction or
current switching position
is indicated.



Temperature sensor



Heating circuit
(Return preheating)



Pump



Backup heating
with burner symbol

4.2 Further indications

Smiley

If the controller operates faultlessly (normal operation), a smiley ☺ is displayed.

Fault indication

If the controller detects a malfunction, the operating control LED flashes red and the symbols of the warning triangle ⚠ and the wrench 🔧 are additionally displayed.

Symbol	Permanently shown	Flashing
Status indications:		
ⓘ	Relay active	
☼	Store maximum limitation active (store maximum temperature has been exceeded)	Collector cooling function active, system cooling or store cooling active
❄	Antifreeze option activated	Collector temp. below minimum temp., antifreeze function active
⚠		Collector emergency shutdown active
⚠ + 🔧		Manual mode active
⚠ + ☼		Store emergency shutdown active
SET		Adjustment mode
COM	SD card is being used	SD card is full
⬆	Indication of the buttons available in the menu item	
☺	Normal operation	
Fault indication:		
⚠ + 🔧		Sensor fault

5 Status level/Measurement values

During normal operation of the controller, the display is in the status level. This one indicates the measurement values shown in the table.

In addition to the display values, possible error messages are indicated in the status level (see page 69).

Display	Description
BLPR1	Blocking protection R1
BLPR2	Blocking protection R2
BLPR3	Blocking protection R3
INIT	Initialisation
FLLT	Filling time
STAB	Stabilisation
TCOL	Temperature collector
TCOL1	Temperature collector 1
TCOL2	Temperature collector 2
TSTB	Temperature store base
TST1B	Temperature store 1 base
TSTT	Temperature store top
TST2B	Temperature store 2 base
TSFL	Temperature solar flow
TSRE	Temperature solar return
TSFB	Temperature solid fuel boiler
TSTR	Temperature store return preheating
TRET	Temperature return
S3	Temperature sensor 3
S4	Temperature sensor 4
S5	Temperature sensor 5
n1	Speed relay 1
n2	Speed relay 2
n3	Speed relay 3
n4	Status relay 4
h R1	Operating hours relay 1
h R2	Operating hours relay 2
h R3	Operating hours relay 3
h R4	Operating hours relay 4

Display	Description
L/h	Flow rate Grundfos Direct Sensor™
BAR	System pressure
TSFL	Temperature solar flow VFS
TSRE	Temperature solar return RPS
TFHQM	Temperature flow heat quantity measurement
TRHQM	Temperature return heat quantity measurement
L/h	Flow rate V40 or flow gauge
kWh	Heat quantity in kWh
TDIS	Disinfection temperature
CDIS	Countdown thermal disinfection
DDIS	Heating period thermal disinfection
TIME	Time
DATE	Date

* R4 is an electromechanical relay not suitable for speed control. Therefore, its status is indicated with 0% or 100% respectively.

6 Commissioning

When the hydraulic system is filled and ready for operation, connect the controller to the mains.

The controller runs an initialisation phase in which all symbols are indicated in the display. The directional pad flashes red.

When the controller is commissioned or when it is reset, it will run a commissioning menu after the initialisation phase. The commissioning menu leads the user through the most important adjustment channels needed for operating the system and starts with the indication of the BX version number.

Commissioning menu

The commissioning menu consists of the channels described in the following. In order to make an adjustment, push button 5. **SET** starts flashing and the adjustment can be made. Acknowledge the message by pressing button 5. Press button 3, the next channel will appear on the screen.

Button navigation

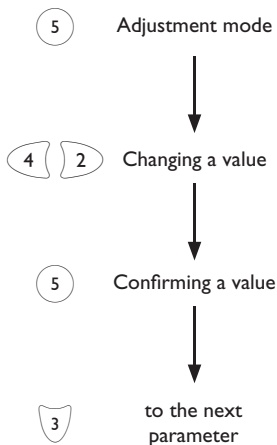

Commissioning

1. Language:

→ Adjust the desired menu language.

2. Temperature unit:

→ Adjust the desired temperature unit.

3. Time:

→ Adjust the clock time. First of all adjust the hours, then the minutes.

4. Date:

→ Adjust the date. First of all adjust the year; then the month and then the day.

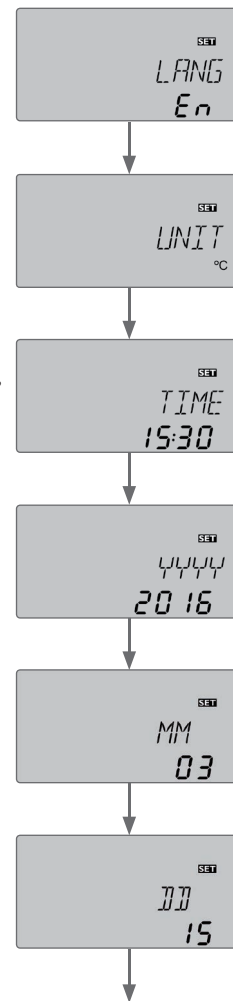

Commissioning

5. Arrangement:

→ Adjust the desired system (see page 46).

6. Maximum store temperature:

→ Adjust the maximum store temperature. In 2-store systems, the adjustment has to be carried out for **S1MAX** and **S2MAX** as well (see page 48).

7. Loading store 2:

→ Switch on or off the “loading store 2” option (see page 48).



Note:

“Loading store 2” is only available if a 2-store system or store loading in layers has been previously selected in the sub-channel **ARR**.

8. Pump control type:

→ Select the pump control type for **PUMP1**. In systems with 2 pumps, carry out this adjustment for **PUMP2** as well.

9. Minimum speed:

→ Adjust the minimum speed of the pump **PUMP1**. In systems with 2 pumps, carry out this adjustment for **PUMP2** as well.



Note:

The minimum speed can only be adjusted if pulse control (PULS) or PWM control (A, B, C) has been selected in the sub-channel **PUMP1,2**.

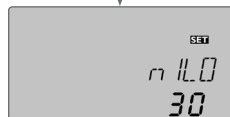
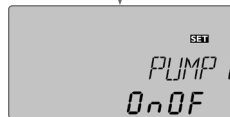
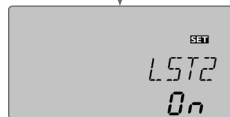
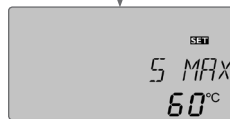
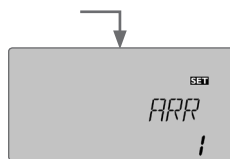

10. Maximum speed:

→ Adjust the maximum speed of the pump **PUMP1**. In systems with 2 pumps, carry out this adjustment for **PUMP2** as well.



Note:

The maximum speed can only be adjusted if pulse control (PULS) or PWM control (A, B, C) has been selected in the sub-channel **PUMP1,2**.

11. Range of the flow rate sensor:

→ Adjust the range of the sensor, if the flow rate sensor is connected.

12. Range of the pressure sensor:

→ Adjust the range of the sensor, if the pressure sensor is connected.

→ **Complete the commissioning menu by pressing button :**

The controller is then ready for operation and normally the factory settings will give close to optimum operation.

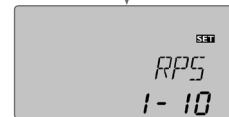
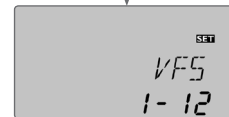
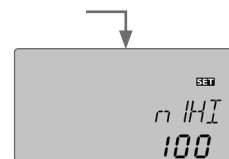

7 Indications, functions and options



Note:

The values and adjustment channels as well as the adjustment ranges depend on the system selected, the functions and options as well as the user code entered and the system components connected to the controller.

An additional document including a list with all options and parameters can be downloaded at www.resol.com.

7.1 Status level

Display of blocking protection time



BLPR(2, 3)

Blocking protection active

Display of drainback time periods

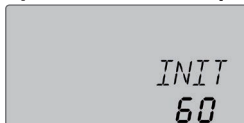

INIT

Initialisation active

Indicates the time adjusted in **tDTP**, running backwards.



FLLT

Filling time active

Indicates the time adjusted in **tFLL**, running backwards.

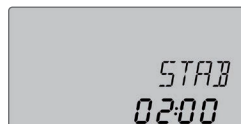

STAB

Stabilisation

Indicates the time adjusted in **tSTB**, running backwards.

Display of collector temperatures



TCOL(2)

Collector temperature

Display range: -40 ... +260 °C

Displays the current collector temperature.

- **TCOL** : Collector temperature (1-collector system)
- **TCOL1**: Collector temperature 1 (2-collector system)
- **TCOL2**: Collector temperature 2 (2-collector system)

Display of store temperatures

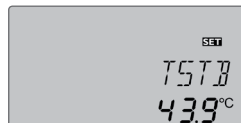

TSTB, etc.

Store temperatures

Display range: -40 ... +260 °C

Displays the current store temperature.

- **TSTB** : Store temperature base
 - **TSTT** : Store temperature top
- in 2-store systems (only if available):
- **TST1T** : Temperature store 1 top
 - **TST1B** : Temperature store 1 base
 - **TST2T** : Temperature store 2 top
 - **TST2B** : Temperature store 2 base

Display of temperatures at S3, S4 and S5

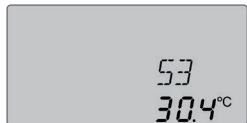

S3, S4, S5

Sensor temperatures

Display range: -40 ... +260 °C

Indicates the current temperature at the corresponding additional sensor (without control function).

- S3 : Temperature sensor 3
- S4 : Temperature sensor 4
- S5 : Temperature sensor 5



Note:

Only if temperature sensors are connected, will S3, S4 and S5 be displayed.



Note:

In systems with return preheating, S3/S5 is used as the heat source sensor **TSTR**.

Display of further temperatures



TSFB, etc.

Further measured temperatures

Display range: -40 ... +260 °C

Indicates the current temperature at the corresponding sensor. The display of these temperatures depends on the system selected.

- TSFB : Temperature solid fuel boiler
- TRET : Temperature heating return
- TSTR : Temperature store return preheating
- TFHQM : Temperature flow (HQM)
- TRHQM : Temperature return (HQM)

Display of flow rate

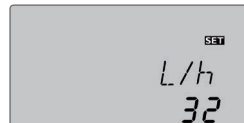

L/h

Flow rate

Display range: 0 ... 9999 l/h

Indicates the currently measured flow rate. The flow rate value is used for calculating the heat quantity supplied (V40/VFS).

Display of pressure



BAR

Pressure

Display range: 0 ... 10 bar

Indicates the current system pressure.



Note:

The pressure will only be indicated if a pressure sensor is used.

Display of speed



n1%, n2%, n3%

Current pump speed

Display range:

30 ... 100% (standard pump)

20 ... 100% (HE pump)

Indicates the current speed of the corresponding pump.

Operating hours counter



hR (1, 2, 3, 4)

Operating hours counter

The operating hours counter accumulates the operating hours of the relay (hR1/hR2/hR3/hR4). Full hours are displayed.

The accumulated operating hours can be set back to zero. As soon as one of the operating hours channels is selected, the symbol **SET** is displayed.

→ In order to access the reset mode of the counter, press the set button (5).

The display symbol **SET** will flash and the operating hours will be set to 0.

→ Confirm the reset with the set button (5) in order to finish the reset.

In order to interrupt the reset process, do not press any button for about 5 s.

The display automatically returns to the display mode.

Display of heat quantity

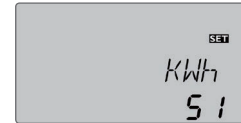

kWh/MWh

Heat quantity in kWh/MWh

Indicates the heat quantity produced in the system. For this purpose, the heat quantity measurement option has to be enabled. The flow rate as well as the values of the reference sensors flow and return are used for calculating the heat quantity supplied. It is shown in kWh in the **kWh** channel and in MWh in the **MWh** channel. The overall heat quantity results from the sum of both values.

The accumulated heat quantity can be set back to zero. As soon as one of the display channels of the heat quantity is selected, the symbol **SET** is displayed.

→ In order to access the reset mode of the counter, press the set button (5) for approx. 2 s.

SET starts flashing and the heat quantity value will be set back to zero.

→ Confirm the reset with the set button in order to finish the reset.

In order to interrupt the reset process, no button should be pressed for about 5 s. The display automatically returns to the display mode.

Indication of thermal disinfection

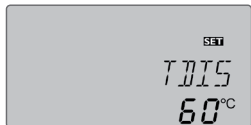

TDIS

Disinfection temperature

Display range: -40 ... +260 °C

If the thermal disinfection option (**OTDIS**) is activated and the disinfection period is in progress, the disinfection temperature measured at the reference sensor is displayed in this channel.

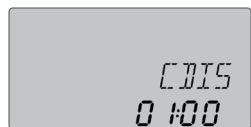

CDIS

Countdown monitoring period

Display range: 0 ... 30:0 ... 24 (dd:hh)

If the thermal disinfection option (**OTDIS**) is activated and the monitoring period is in progress, the remaining time of the monitoring period is displayed as **CDIS** (in days and hours), counting backwards.

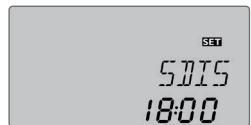

SDIS

Starting time

Display range: 0:00 ... 24:00 (time)

If the thermal disinfection option (**OTDIS**) is activated and a starting delay time has been adjusted, the delay time is displayed (flashing) in this channel.



DDIS

Disinfection period

Display range: 0:00 ... 23:59 (hh:mm)

If the thermal disinfection option (**OTDIS**) is activated and the disinfection period is in progress, the remaining time of the heating period is displayed (in hours and minutes) in this channel, counting backwards.

Display of time

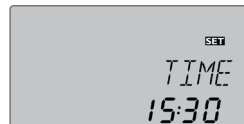

TIME

Time

Indicates the current clock time.

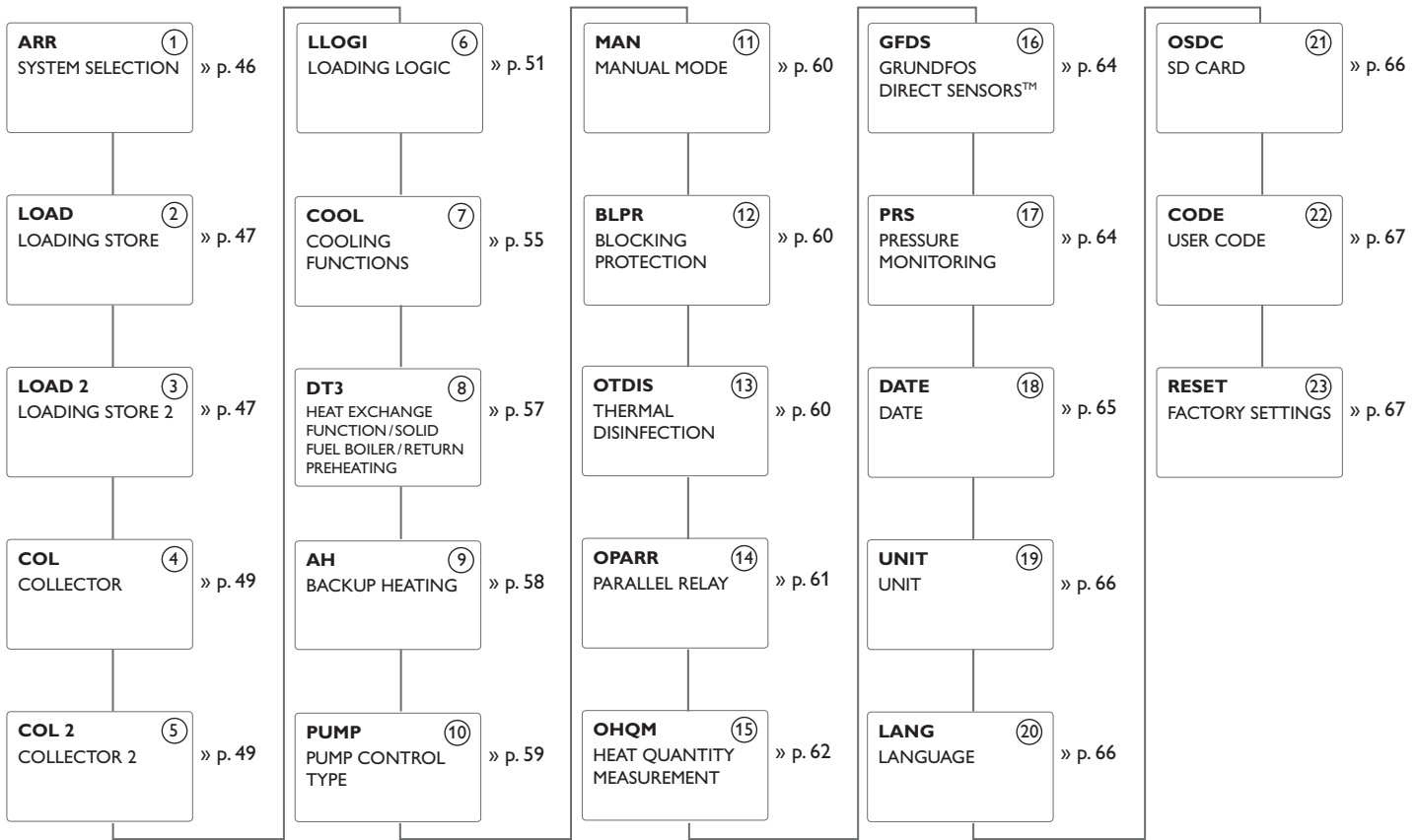

Parameters shown in the following with a dashed line depend on options and are only indicated if they are available in the system selected.

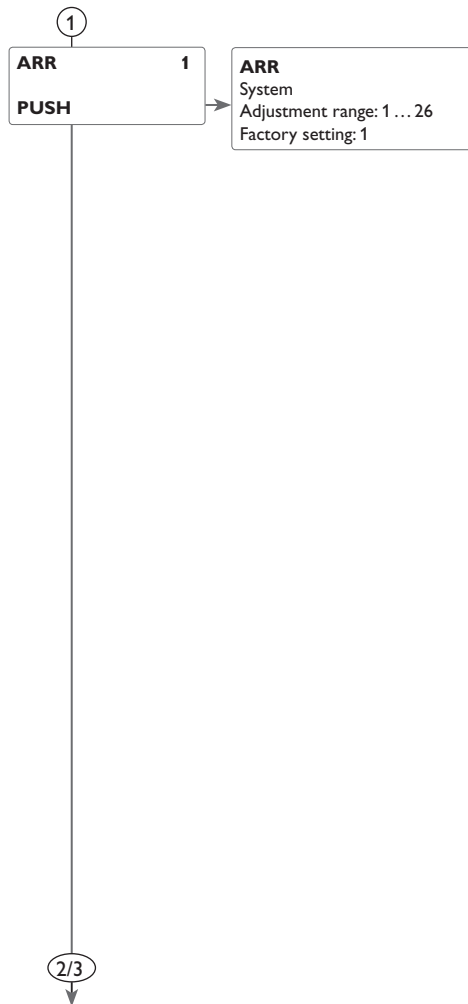
**Note:**

If the controller is commissioned for the first time, the commissioning menu will start. The subsequent selection of a new system will reset all other adjustments to the factory settings.

① System**Selecting the system**

Selection of the appropriate system. Each system has pre-programmed options and adjustments which can be activated or changed respectively if necessary. Select the system first (see page 35).

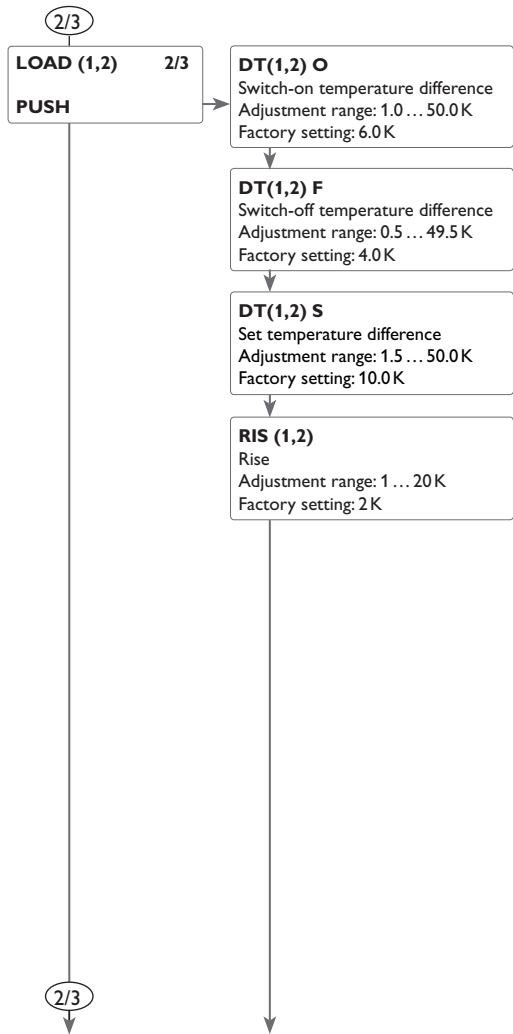

2/3 ΔT control

The controller works as a standard differential controller. If the temperature reaches or exceeds the switch-on temperature difference, the pump switches on. When the temperature difference reaches or falls below the adjusted switch-off temperature difference, the respective relay switches off.



Note:

The switch-on temperature difference must be 0.5 K higher than the switch-off temperature difference. The set temperature difference must be at least 0.5 K higher than the switch-on temperature difference.



Note:

In systems with 2 stores or store loading in layers, 2 separate menus (**LOAD** and **LOAD 2**) will be displayed.

Speed control

If the temperature difference reaches or exceeds the switch-on temperature difference, the pump switches on at 100% speed for 10 s. Then, the speed is reduced to the minimum pump speed value.

If the temperature difference reaches the adjusted set value, the pump speed increases by one step (10%). The response of the controller can be adapted via the parameter **RIS**. Each time the difference increases by the adjustable rise value, the pump speed increases by 10 % until the maximum pump speed of 100% is reached. If the temperature difference decreases by the adjustable rise value, pump speed will be decreased by one step.



Note:

To enable speed control, the corresponding relay has to be set to **AUTO** or **nLO**, **nHI** (adjustment channel **MAN**) and the pump control type has to be set to **PULS**, **PWM A**, **b**, or **C** (adjustment channel **PUMP**).

2/3

↓

S(1,2)MAX
 Maximum store temperature
 Adjustment range: 4...95 °C
 Factory setting: 60 °C

↓

SMXS1(2)
 Sensor maximum store temperature
 Adjustment range:
 1-store system S2, S3
 2-store system S4, S5
 Factory setting:
 1-store system S2
 2-store system S4

↓

LST2
 Loading store 2
 Selection: ON/OFF
 Factory setting: ON

4/5

2/3 Store maximum temperature and Sensor store maximum temperature

If the store temperature reaches the adjusted maximum temperature, the store will no longer be loaded in order to avoid damage caused by overheating. If the maximum store temperature is exceeded, ✱ is displayed.

The sensor for store maximum limitation can be selected. The maximum limitation always refers to the sensor selected.

Switch-on hysteresis: -2 K

If S3 is selected, the differential control will be carried out using S1 and S2. The temperature at S2 can exceed the adjusted limit temperature, the system will not switch off. If the value at S3 reaches the limit temperature, the system will be switched off.



Note:

In systems with 2 stores or store loading in layers, 2 separate menus (**LOAD** and **LOAD 2**) will be displayed.

Loading store 2

In a 2-store system, the second store can be switched off for loading via the parameter LST2.

If **LST2** is adjusted to **OFF**, the system runs like a 1-store system. The representation in the display remains the same.

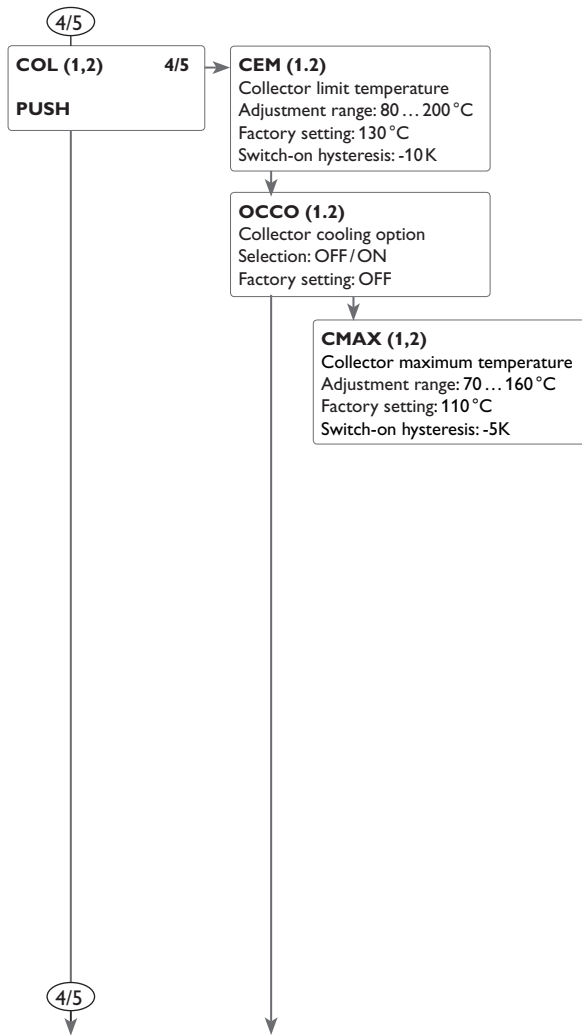

4/5 Collector emergency shutdown

When the collector temperature exceeds the adjusted collector limit temperature, the solar pump (R1/R2) switches off in order to protect the system components against overheating (collector emergency shutdown). If the collector limit temperature is exceeded, Δ is displayed (flashing).



Note:

If the drainback option is activated, the adjustment range of the collector emergency temperature is changed to 80 ... 95 °C. Factory setting will be 95 °C.



Note:

In systems with east-/west collectors 2 separate menus (**COL** and **COL2**) will be displayed.

WARNING! Risk of injury! Risk of system damage by pressure surge!



If water is used as the heat transfer fluid in pressureless systems, water will boil at 100 °C.

→ In pressureless systems with water as the heat transfer fluid, do not set the collector limit temperature higher than 95 °C.

Collector cooling

The collector cooling function keeps the collector temperature within the operating range by heating the store. If the store temperature reaches 95 °C the function will switch off for safety reasons.

If the store temperature exceeds the adjusted maximum store temperature, the solar system is switched off. If the collector temperature increases to the adjusted maximum collector temperature, the solar pump is activated until the collector temperature falls below the maximum collector temperature. The store temperature may then exceed the maximum temperature, but only up to 95 °C (emergency shutdown of the store).

If the collector cooling is active, \star is displayed (flashing).



Note:

This function is only available if the system cooling function and the heat dump function are not activated.



Note:

In systems with east-/west collectors 2 separate menus (**COL** and **COL2**) will be displayed.

4/5

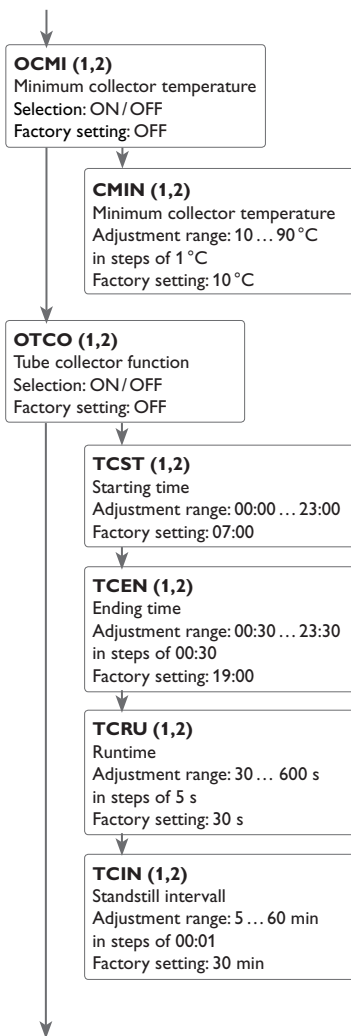

4/5

4/5 Collector minimum temperature

The minimum collector temperature is the minimum switch-on temperature which must be exceeded for the solar pump (R1/R2) to switch on. If the collector temperature falls below the adjusted minimum temperature, ☼ is displayed (flashing).



Note:

In systems with east-/west collectors 2 separate menus (**COL** and **COL2**) will be displayed.

Tube collector function

This function is used for improving the switch-on behaviour in systems with non-ideal sensor positions (e. g. with some tube collectors).

This function operates within an adjusted time frame. It activates the collector circuit pump for an adjustable runtime between adjustable standstill intervals in order to compensate for the delayed temperature measurement.

If the runtime is set to more than 10 seconds, the pump will be run at 100% for the first 10 s of the runtime. For the remaining runtime, the pump will be run at the adjusted minimum speed.

If the collector sensor is defective or the collector is blocked, this function is suppressed or switched off.

2-collector systems

In 2-collector systems, the tube collector function is available for each individual collector field.

In 2-collector systems, the tube collector function will affect the inactive collector field only. The solar pump of the active collector field will remain switched on until the switch-off conditions are fulfilled.



Note:

If the drainback option is activated, the tube collector function will not be available.

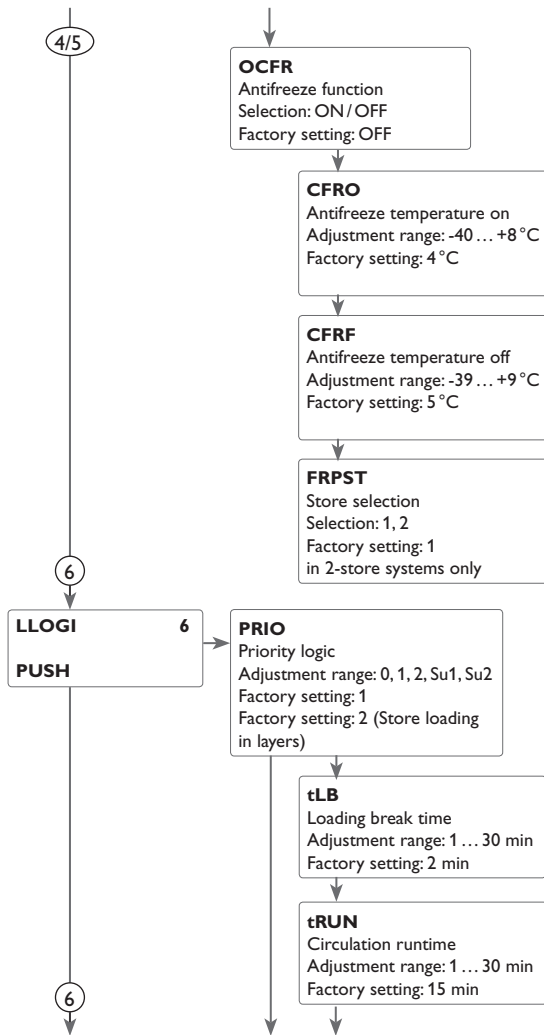

4/5 Antifreeze function

The antifreeze function activates the loading circuit between the collector and the store when the collector temperature falls below the adjusted temperature **CFRO**. This will protect the fluid against freezing or coagulating. If **CFRF** is exceeded, the solar pump will be switched off again.

The antifreeze function will be suppressed if the store temperature of the selected store falls below 5 °C. In 2-store systems, the function will switch to the second store, in systems with store loading in layers, it will switch to the upper store zone. If the temperature of the second store (or of the upper store zone respectively) also falls below 5 °C, the system will be switched off.



Note:

In systems with east-/west collectors, the antifreeze function will work on both collector fields.



Note:

Since this function uses the limited heat quantity of the store, the antifreeze function should be used in regions with few days of temperatures around the freezing point.

6 Priority logic

Priority logic can be used in 2-store systems or systems with store loading in layers only and determines how the heat is divided between the stores.

Different types of priority logic are adjustable:

- store sequence control (1 and 2)
- successive loading (Su 1 and Su 2)
- parallel loading (0)

1. If **PRIO 1** or **2** is adjusted, the corresponding store (1 = store 1/store top; 2 = store 2/store base) will be loaded with priority if its switch-on conditions are fulfilled and if it is not blocked. If the priority store is not blocked but its switch-on conditions are not fulfilled, the store sequence control starts provided that the switch-on conditions of the subordinate store are fulfilled. If a subordinate store can be loaded, it will be loaded for the oscillating loading time **tRUN**. After the loading time has ended, the pump is switched off for the loading break **tLB**. If during this time the priority store can be loaded, it will be loaded. If the priority store has reached its maximum temperature, the subordinate store will be loaded up to its maximum temperature without store sequence control.

6

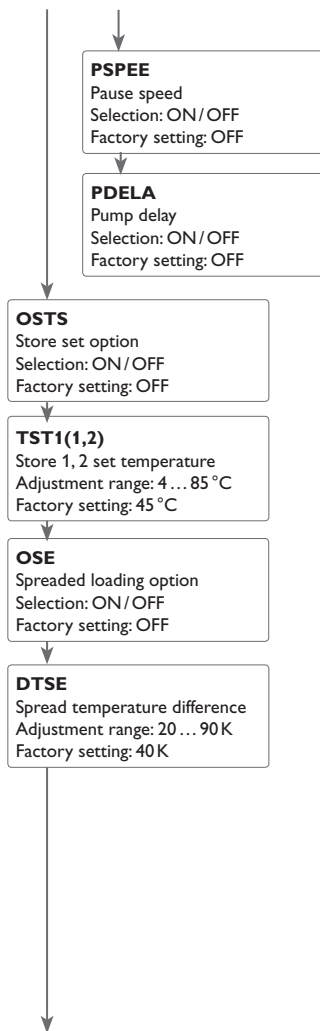

6

- If priority **Su 1** or **Su 2** is adjusted, the priority store will be loaded up to its maximum temperature. If the maximum temperature is reached, the second store will be loaded. If the temperature of the first store falls below **SMAX**, the second store will no longer be loaded, regardless of whether the switch-on conditions of the priority store or of the subordinate store are fulfilled or not.
- In systems with 2 pumps, both stores will be loaded if the corresponding switch-on conditions are fulfilled if **PRIO 0** is adjusted. In systems with 3-port valves, the store with the lowest temperature will be loaded first until its temperature is by 5 K above the other store. Loading will be switched to the other store. Then, the 2 stores will be loaded alternately in steps of 5 K.

Successive loading option

Successive loading means that the priority store will be loaded up to its maximum temperature. If it is reached, the second store will be loaded. If the temperature of the first store falls below the maximum temperature, the second store will no longer be loaded, regardless of whether the switch-on conditions of the priority store or of the subordinate store are fulfilled or not.

Spreaded loading option

In 2-store systems with 2 pumps, a spreaded loading function can be activated: As soon as the adjustable temperature difference **DTSE** between the collector and the priority store is reached, the second store will be loaded in parallel unless it is blocked. If the temperature difference falls by 2K below **DTSE**, the pump is switched off. The collector temperature has to be higher than the store temperature.

Loading logic

In systems with 2 stores or store loading in layers, store sequence control can be adjusted. In 1-store systems, only the menu item **PDELA** will be available.

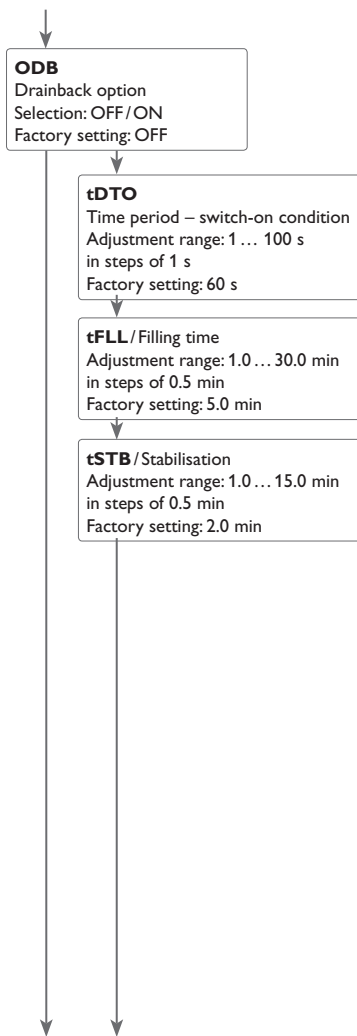

6 Drainback option

In a drainback system the heat transfer fluid will flow into a holding tank if solar loading does not take place. The drainback option initiates the filling process if solar loading is about to start. If the drainback option is activated, the following adjustment can be made.



Note:

A drainback system requires additional components such as a holding tank. The drainback option should only be activated if all components required are properly installed.

Time period – switch-on condition

The parameter **tDTO** is used for adjusting the time period during which the switch-on condition must be permanently fulfilled.

Filling time

The filling time can be adjusted using the parameter **tFLL**. During this period, the pump runs at 100% speed.

Stabilisation

The parameter **tSTB** is used for adjusting the time period during which the switch-off condition will be ignored after the filling time has ended.



Note:

If the drainback option is activated, the cooling functions and the anti-freeze function will not be available.



Note:

The drainback option is only available in systems with 1 store and 1 collector field and if no cooling function is activated.

6

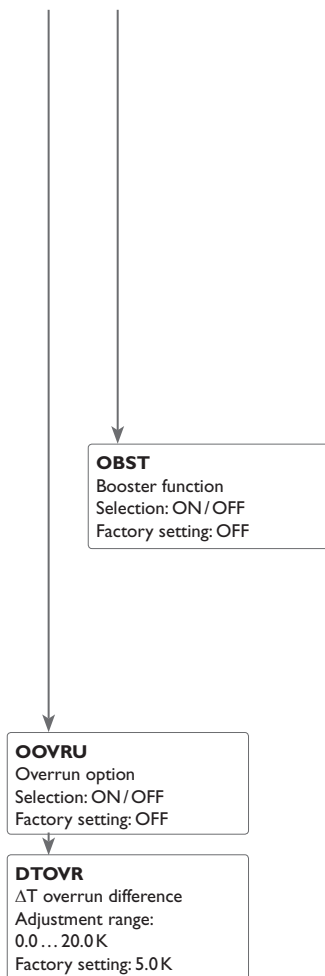

7

6

**Note:**

If the drainback function **ODB** is activated, the factory settings of the parameters **DT O**, **DT F** and **DT S** will be adapted to values suiting drainback systems:

DT O = 10 K

DT F = 4 K

DT S = 15 K

Additionally, the adjustment range and the factory setting of the collector emergency shutdown **CEM** will change:

Adjustment range: 80 ... 120 °C; Factory setting: 95 °C

Adjustments previously made in these channels will be overridden and have to be entered again if the drainback option is deactivated later on.

**Note:**

If the holiday function is activated, the drainback option will not be available.

Booster function

This function is used for switching on a second pump when filling the solar system. When solar loading starts, R3 is energised in parallel to R1. After the filling time has elapsed, R2 switches off.

**Note:**

The booster function is available in systems 1, 2, 3, 8, 9 and 10 only.

**Note:**

The overrun function is only available, if both Grundfos Direct Sensors™ (VFS and RPS) are used.

Overrun

By means of this function, store loading continues after the temperature difference between the collector and the store has fallen below the switch-off difference. It switches off if the temperature difference between the allocated flow and return sensors falls below the switch-off difference **DT(1,2) F**.

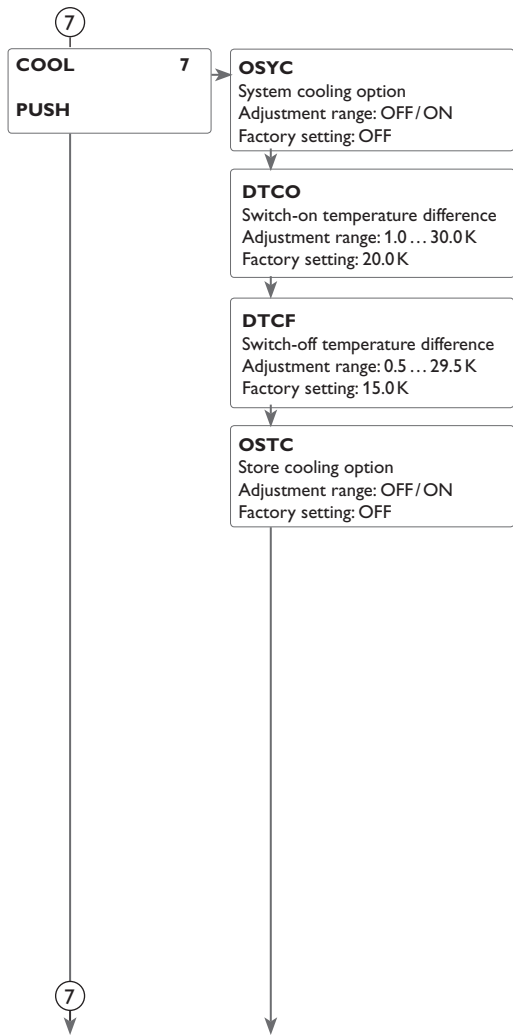

⑦ Cooling functions

Different cooling functions can be activated: system cooling, store cooling and heat dump.



Note:

If the temperature at the store sensor reaches 95 °C, all cooling functions will be blocked. The switch-on hysteresis is -2K.



Note:

If one of the cooling functions or the antifreeze function is activated, the drainback option will not be available.

System cooling

The system cooling function aims to keep the solar system operational for a longer time. The function overrides the maximum store temperature to provide thermal relief of the collector field and the heat transfer fluid on hot days.

If the store temperature is higher than the adjusted maximum store temperature and the switch-on temperature difference **DTCO** is reached, the solar pump remains switched on or will be switched on. Solar loading is continued until either the temperature difference falls below the adjusted value **DTCF** or the collector limit temperature is reached.

In 2-store systems the sequence of the stores can be adjusted.

If the system cooling is active, ☼ is displayed (flashing).



Note:

This function will only be available if the collector cooling function, the heat dump function, and the drainback option are not activated.

Store cooling

When the store cooling function is activated, the controller aims to cool down the store during the night in order to prepare it for solar loading on the following day. If the adjusted maximum store temperature is exceeded and the collector temperature falls below the store temperature, the system will be reactivated in order to cool down the store.

DT O and **DT F (LOAD 1/2)** are used as the reference temperature differences.

7

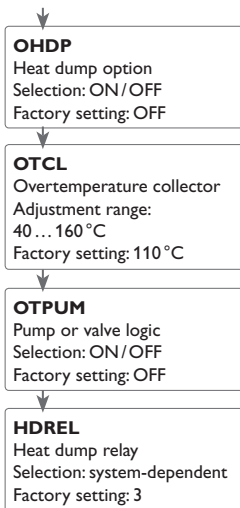

8

7 Heat dump

The Heat dump function can be used to direct excess heat generated by strong solar irradiation to an external heat exchanger (e. g. fan coil) in order to keep the collector temperature within the operating range.

The heat dump function can either use an additional pump or valve (**OTPUM ON** = pump logic, **OTPUM OFF** = valve logic).

Variant pump:

The allocated relay is energised with 100%, if the collector temperature reaches the adjusted switch-on temperature.

If the collector temperature falls by 5 K below the adjusted collector overtemperature, the relay will be switched off. In the variant pump, the heat dump function works independently from solar loading.

Variant valve:

The allocated relay will be energised in parallel to the solar pump, if the collector temperature reaches the adjusted collector overtemperature. If the collector temperature falls by 5 K below the adjusted collector overtemperature, the relay will be switched off.



Note:

The adjustable value **OTCL** is blocked against the collector emergency temperature **CEM** by 10K This function will only be available if the collector cooling function, the heat dump function, and the drainback option are deactivated.

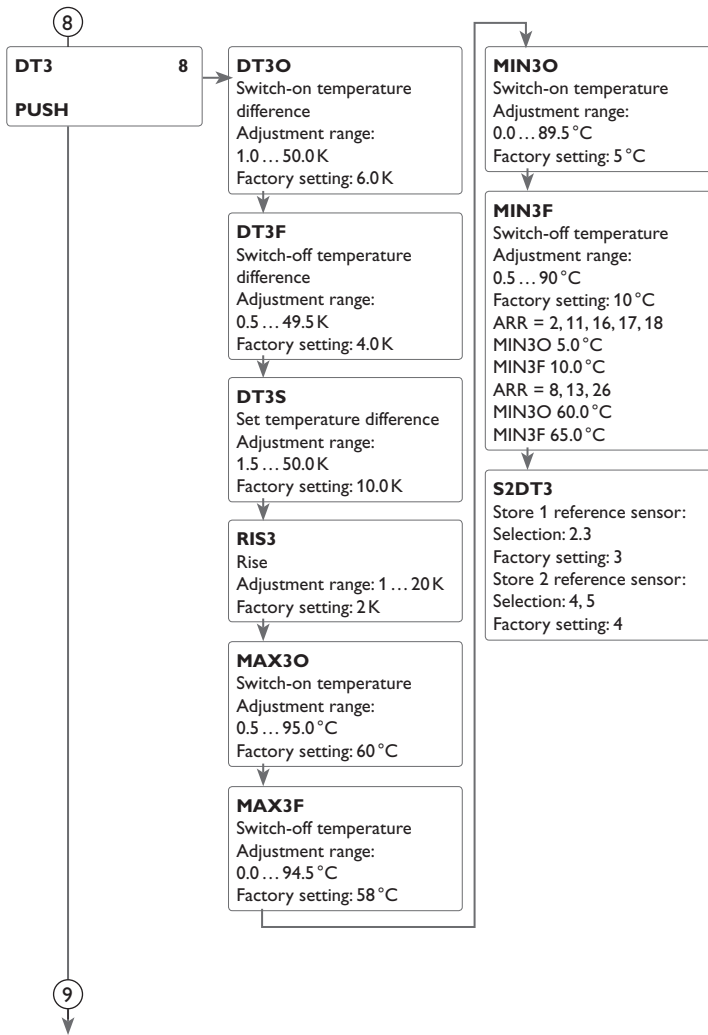

⑧ DT3/Heat exchange function/Solid fuel boiler/Return preheating

Heat exchange function

The Heat exchange function can be used for transferring heat from a heat source to a heat sink.

The relay (system-dependent) is energised when all switch-on conditions are fulfilled:

- the temperature difference between the sensors heat source and heat sink has exceeded the switch-on temperature difference.
- the temperature at the heat source sensor has exceeded the minimum temperature
- the temperature at the heat sink sensor has fallen below the maximum temperature

When the Set temperature difference is exceeded, pump speed control starts. For every increase or decrease by the rise value, the pump speed will be adjusted by 10%.

Solid fuel boiler

The Solid fuel boiler function can be used for transferring heat from a solid fuel boiler to a store.

The relay (system-dependent) is energised when all switch-on conditions are fulfilled:

- the temperature difference between the sensors heat source and heat sink has exceeded the switch-on temperature difference.
- the temperature at the solid fuel boiler sensor has exceeded the minimum temperature
- the temperature at the store sensor has fallen below the maximum temperature

When the Set temperature difference is exceeded, pump speed control starts.

For every increase or decrease by the rise value, the pump speed will be adjusted by one step (10%).

Return preheating

The Return preheating function can be used for transferring heat from a heat source to the heating circuit return.

The relay (system-dependent) is energised when the following switch-on condition is fulfilled:

- the temperature difference between the sensors store return and heating circuit return has exceeded the switch-on temperature difference.

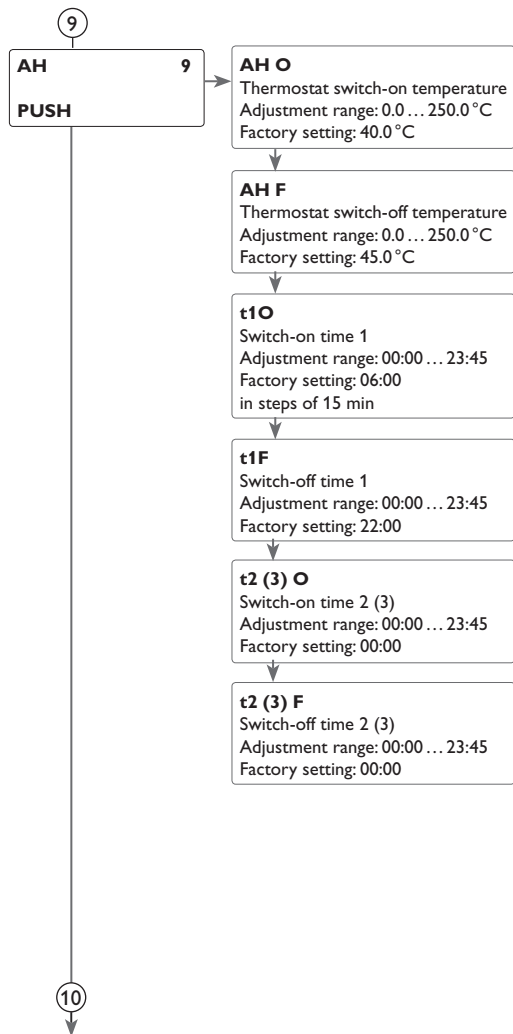

9 Backup heating/Thermostat function

The thermostat function works independently from the solar operation and can e.g. be used for using surplus energy or for backup heating.

- **AHO < AHF**
thermostat function for backup heating
- **AHO > AHF**
thermostat function for using surplus energy

In order to block the thermostat function for a certain period, there are 3 time frames t1 ... t3. The switch-on and switch-off times can be adjusted in steps of 15 min. If the switch-on and the switch-off times are identical, the time frame is inactive.

If the thermostat function is supposed to run from 06:00 a.m. and 09:00 a.m. only, adjust t1 O to 06:00 a.m. and t1 F to 09:00 a.m.

The first time frame is factory set from 06:00 to 22:00.

If all time frames are set to 00:00, the thermostat function is solely temperature dependent.

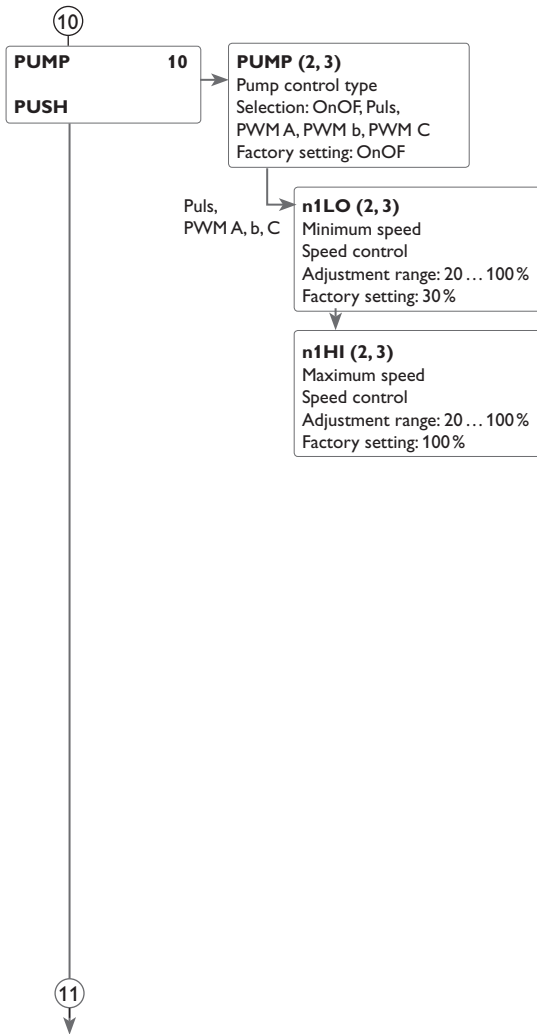

⑩ Pump control type

With this parameter, the relay control type can be adjusted. The following types can be selected:

Adjustment for standard pump without speed control

- OnOF: Pump on / pump off

Adjustment for standard pump with speed control

- PULS : Burst control via semiconductor relay

Adjustment for high-efficiency pump (HE pump)

- PWMA (Wilo) (for R1 and R2 only)
- PWM b (Grundfos) (for R1 and R2 only)
- PWM C (Laing) (for R1 and R2 only)



Note:

For more information about connecting HE pumps, see page 35.

Relay allocation for PWM outputs

PWM1 is allocated to R1, PWM2 is allocated to R2.

Minimum speed

In the adjustment channel **n1Lo (2,3)**, a relative minimum speed for a connected pump can be allocated to the outputs R1, R2 and R3.



Note:

When loads which are not speed-controlled (e. g. valves) are used, the pump speed value of the corresponding relay must be set to 100% or the control type must be set to OnOF in order to deactivate pump speed control.

Maximum speed

In the adjustment channel **n1HI (2,3)**, a relative maximum speed for a connected pump can be allocated to the outputs R1, R2 and R3.



Note:

When loads which are not speed-controlled (e. g. valves) are used, the pump speed value of the corresponding relay must be set to 100% or the control type must be set to OnOF in order to deactivate pump speed control.

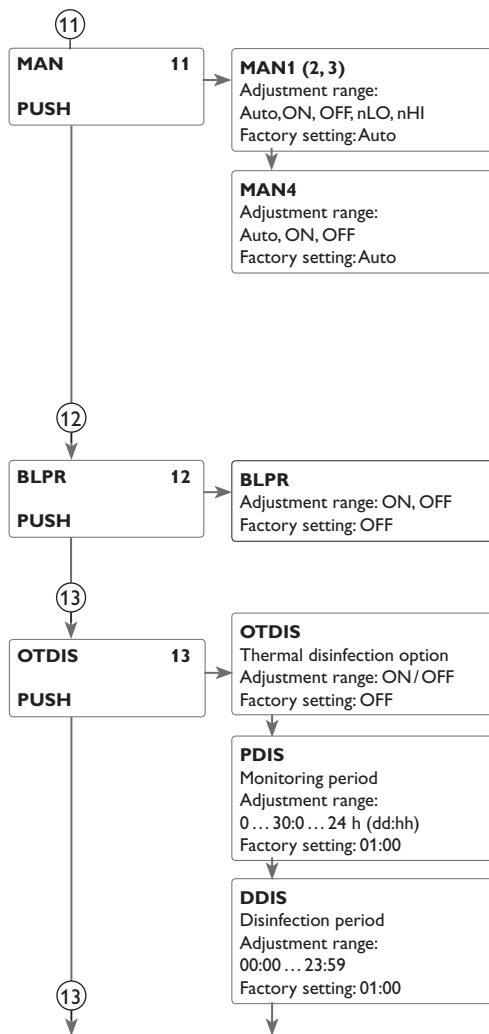

11 Manual mode

For control and service work, the operating mode of the relays can be manually adjusted. For this purpose, select the adjustment channel MAN1(2, 3, 4) (for R1, 2, 3, 4) in which the following adjustments can be made:

Operating mode

AUTO : relay in automatic mode

OFF : relay is switched off

n1LO : relay is switched with adjusted minimum speed (not if PUMP = OnOF)

n1HI : relay is switched with adjusted maximum speed



Note:

After service and maintenance work, set the relay mode back to **AUTO**. Normal operation is not possible in manual mode.

12 Blocking protection

In order to protect the pumps against blocking after standstill, the controller is equipped with a blocking protection function. This function switches on the relays one after another every day at 12:00 a.m. for 10s at 100%.

13 Thermal disinfection

This function helps to contain the spread of Legionella in DHW stores by systematically activating the backup heating.

One sensor and one relay can be selected for this function.

For thermal disinfection, the temperature at the allocated sensor has to be monitored. Protection is ensured when, during the monitoring period, the disinfection temperature is continuously exceeded for the entire disinfection period.

The monitoring period starts as soon as the temperature at the allocated sensor falls below the disinfection temperature. When the monitoring period ends, the allocated reference relay activates the backup heating. The disinfection period starts, if the temperature at the allocated sensor exceeds the disinfection temperature.

Thermal disinfection can only be completed when the disinfection temperature is exceeded for the duration of the disinfection period without any interruption.

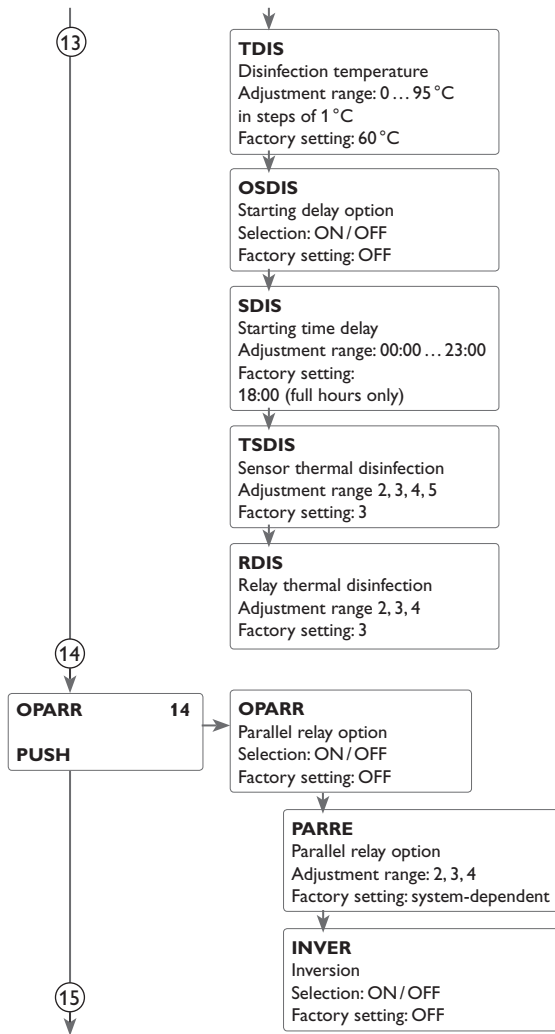

13 Starting time delay

If the starting delay option is activated, a starting time for the thermal disinfection with starting delay can be adjusted. The activation of the backup heating is then delayed until that starting time after the monitoring period has ended.

If the monitoring period ends, for example, at 12:00 o'clock, and the starting time has been set to 18:00, the reference relay will be energised with a delay of 6 hours at 18:00 instead of 12:00 o'clock.



Note:

If the thermal disinfection option is activated, the display channels **TDIS**, **CDIS**, **SDIS** and **DDIS** will be displayed.

14 Parallel relay

With this function, e. g. a valve can be controlled in parallel to the pump via a separate relay.

If solar loading takes place (R1 and/or R2) or if a solar function is active, the relay selected will be energised. The parallel relay can also be energised inversely.



Note:

If R1 and/or R2 are in the manual mode, the selected parallel relay will not be energised.

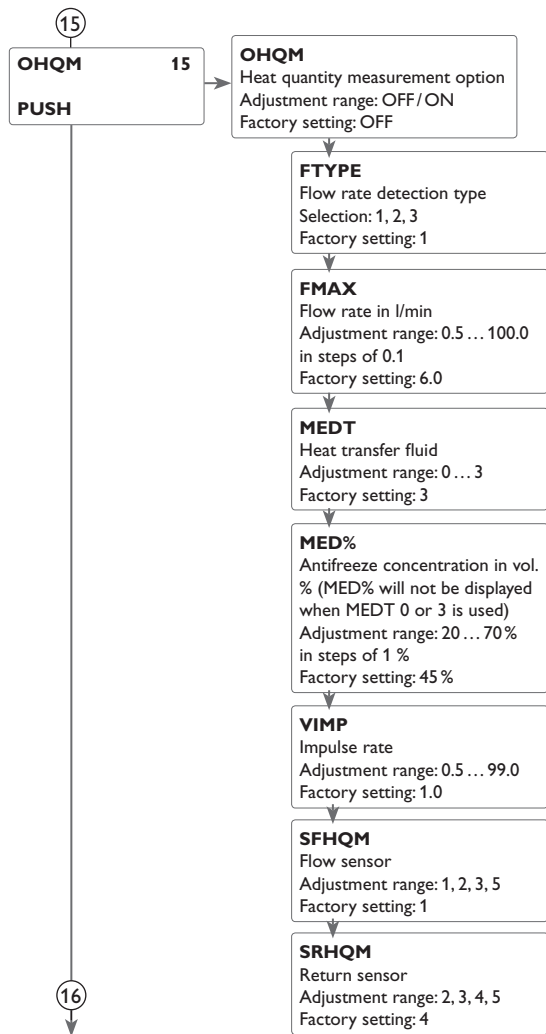

15 Heat quantity measurement

The heat quantity measurement can be carried out in 3 different ways: without V40 flowmeter, with V40 flowmeter or with Grundfos Direct Sensor™.



Note:

The most precise heat quantity measurement is achieved by using sensors in the flow and return pipes as well as a flowmeter.

In 2-collector systems, heat quantity measurement can only be carried out with sensors installed in the common flow and return pipes.

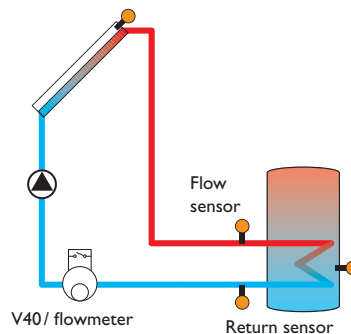

Example of flow and return sensor positions for heat quantity measurement with a fixed flow rate value (flowmeter) or a V40 flowmeter.

- ➔ Enable the heat quantity measurement option in the channel **OHQM**.
- ➔ Select the type of flow rate detection in the channel **FTYPE**.

Flow rate detection type:

- 1 : Fixed flow rate value (flowmeter)
- 2 : V40
- 3 : Grundfos Direct Sensor™ VFS

15) Heat quantity measurement with fixed flow rate value

The heat quantity balancing (estimation) uses the difference between the flow and return temperatures and the entered flow rate (at 100% pump speed).

- Adjust **1** in the channel **FTYPE**.
- Read the flow rate (l/min) and adjust it in the **FMAX** channel.
- Adjust the antifreeze type and concentration of the heat transfer fluid in the channels **MEDT** and **MED%**.



Note:

Heat quantity measurement with a fixed flow rate value is not possible in systems with 2 solar pumps.

Antifreeze type:

- 0 : Water
- 1 : Propylene glycol
- 2 : Ethylene glycol
- 3 : Tyfocor® LS/G-LS

Heat quantity measurement with V40 flowmeter:

The heat quantity measurement uses the difference between the flow and return temperatures and the flow rate transmitted by the flowmeter.

- Adjust **2** in the channel **FTYPE**.
- In the channel **FIMP**, adjust the impulse rate corresponding to the V40 flowmeter used.
- Adjust the antifreeze type and concentration of the heat transfer fluid in the channels **MEDT** and **MED%**.

Heat quantity measurement with Grundfos Direct Sensor™:

The heat quantity measurement uses the difference between flow and return temperature and the flow rate transmitted by the VFS sensor.

- Adjust **3** in the channel **FTYPE**.
- Adjust the antifreeze type and concentration of the heat transfer fluid in the channels **MEDT** and **MED%**.



Note:

If variant 3 is selected, the sensors must first be activated in the **GFDS** menu item (see page 64).

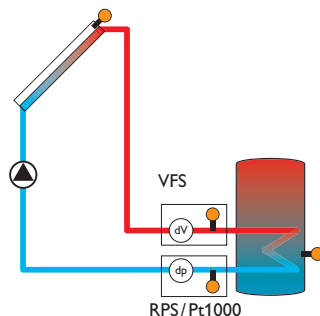

HQM sensors

If the flow rate detection type 1, 2, or 3 (flowmeter, V40, or Grundfos Direct Sensor™ VFS) has been adjusted, the flow and the return sensor for heat quantity measurement can be selected.

- In the channel **SFHQM** select the flow sensor.
 - In the channel **SRHQM** select the return sensor.
- For this function, free sensors at an appropriate position can be selected.

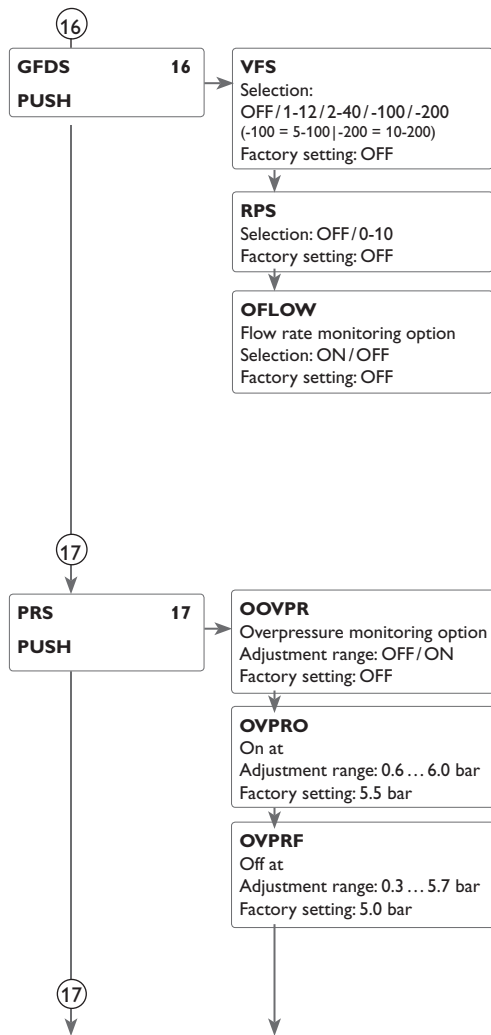

16 Grundfos Direct Sensors™

In this menu the Grundfos Direct Sensors™ can be registered.

For Grundfos Direct Sensor™ positioning, see the system layout drawing on p. 63!

If Grundfos Direct Sensors™ are connected and registered, flow rate monitoring **OFLOW** can be carried out during solar loading. For that purpose, the VFS sensor must be installed in the solar flow. If no flow rate has been detected for 30 s, the error message **EFLOW** is displayed in the status menu (see flow rate monitoring option).



Note:

To deactivate a Grundfos Direct Sensor™, the functions using this sensor have to be deactivated first.

Flow rate monitoring

The Flow rate monitoring function can be used to detect malfunctions that impede the flow rate. This will prevent system damage, e. g. through a dry run of the pump.



Note:

To deactivate the VFS or RPS sensor, the functions using this sensor have to be deactivated first.

17 Pressure monitoring



Note:

The pressure monitoring function will only be available when an RPD type Grundfos Direct Sensor™ is connected.

The Pressure monitoring function can be used for detecting overpressure or low pressure conditions inside the system. This will prevent system damage.

Overpressure

If the system pressure exceeds the adjustable switch-on value, an error message will appear.

When the pressure reaches or falls below the adjustable switch-off value, the message disappears.



Note:

For the **Overpressure monitoring** function, the switch-on value has to be adjusted at least 0.1 bar higher than the switch-off value. The adjustment ranges will automatically adapt to that.

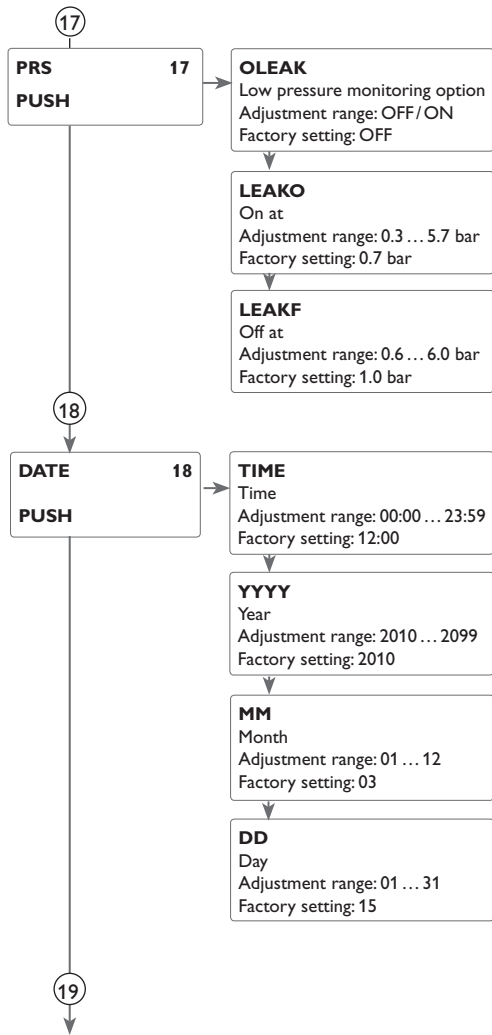

Low pressure (leakage)

If the system pressure falls below the adjustable switch-on value, an error message will appear.

When the pressure reaches or exceeds the adjustable switch-off value, the message disappears.



Note:

For the **Low pressure monitoring** function, the switch-off value has to be adjusted at least 0.1 bar higher than the switch-on value. The adjustment ranges will automatically adapt to that.

18 Time and date

The controller is equipped with a real time clock required e.g. for the thermostat function.

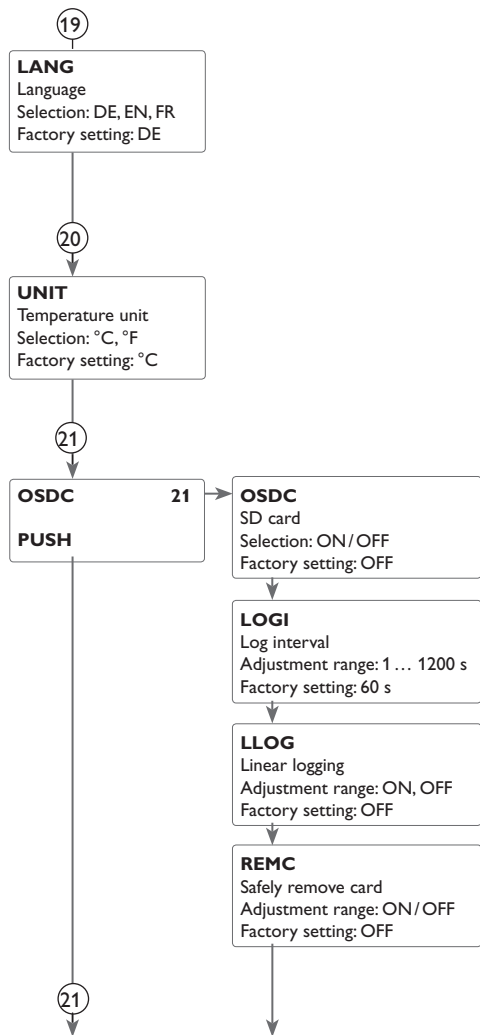

19 Language

In this adjustment channel the menu language can be selected.

- DE : German
- EN : English
- FR : French

20 Units

In this adjustment channel the temperature unit can be selected.

The unit can be switched between °C and °F during operation.

21 SD card

The controller is equipped with an SD card slot for SD memory cards.

With an SD card, the following functions can be carried out:

- Logging measurement and balance values. After the transfer to a computer, the values can be opened and visualised, e. g. in a spreadsheet.

While an SD card is being used, the symbol **COM** will be displayed. If the SD card is full, **COM** will start flashing.

Starting the logging

➔ Insert the SD card into the slot.

Logging will start immediately.

➔ Adjust the desired logging interval **LOGI**.

When **LLOG** is activated, data logging will stop if the capacity limit is reached. The message **CFULL** will be displayed.

With non-linear logging (when **LLOG** is deactivated), the oldest data logged onto the SD card will be overwritten as soon as the capacity limit is reached.

Completing the logging process

➔ Select the menu item **REMC**.

➔ After **--REM** is displayed remove the card from the slot.

21

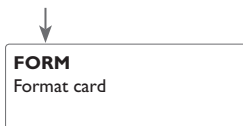

22



23



21 Formatting the SD card

→ Select the menu item **FORM**.

→ During the formatting process, **--FORM** will be displayed.

The content of the card will be deleted and the card will be formatted with the FAT file system.

Messages possible	Description
FSYS	File system error
CTYP	Card type is not supported
WRIT	Error during writing
NOCRD	No card in slot
LOGG	Logging is possible
WRITP	Card is write-protected
CFULL	Card full
RTIME	Remaining logging time in days
REMC	Safely remove card command
--REM	Card is being removed
FORM	Formatting SD card command
--FORM	Formatting in progress
LOGI	Logging interval in min
LLOG	Linear logging



Note:

Because of the increasing size of the data packets, the remaining logging time does not decrease linearly. The data packet size can increase, e. g. with the increasing operating hours value.

22 Code

The user code can be entered in the **CODE** menu (see page 68).

23 Reset

By means of the reset function, all adjustments can be set back to the factory settings. To do so, the installer code must be entered (see page 68).

8 User code and short menu – Adjustment values

CODE

The access to some adjustment values can be restricted via a user code (customer).

1. Installer **0262** (Factory setting)

All menus and adjustment values are shown and all values can be altered.

2. Customer **0000**

The installer level is not shown, adjustment values can be changed partly.

For safety reasons, the user code should generally be set to the customer code before the controller is handed to the customer!

➔ In order to restrict the access, enter 0000 in the menu item **CODE**.

The display changes to the status level. The short menu shown will then be available in the adjustment level. The short menu suits the selected system.

➔ In order to authorise access to the installer level, enter 0262 in the menu item **CODE**.

Short menu

Channel	Factory setting	Adjustment range	Designation
TIME	12:00	00:00 ... 23:59	Time
DT O	6	1.0 ... 50.0	Switch-on temperature difference store
DT F	4	0.5 ... 49.5	Switch-off temperature difference store
DT S	10	1.0 ... 50.0	Set temperature difference store
S MAX	60	4 ... 95	Store maximum limitation
DT1O	6	1.0 ... 50.0	Switch-on temperature difference store 1
DT1F	4	0.5 ... 49.5	Switch-off temperature difference store 1
DT1S	10	1.0 ... 50.0	Set temperature difference store 1
S1MAX	60	4 ... 95	Store maximum limitation store 1
DT2O	6	1.0 ... 50	Switch-on temperature difference store 2
DT2F	4	0.5 ... 49.5	Switch-off temperature difference store 2
DT2S	10	1.5 ... 50.0	Set temperature difference store 2
S2MAX	60	4 ... 95	Store maximum limitation store 2
LST2	On	On / OFF	Loading store 2 on
MAN1	Auto	Auto / On / OFF / n LO / n HI	Manual mode pump 1
MAN2	Auto	Auto / On / OFF / n LO / n HI	Manual mode pump 2
MAN3	Auto	Auto / On / OFF / n LO / n HI	Manual mode pump 3
MAN4	Auto	Auto / On / OFF	Manual mode pump 4
CODE	0000	0000 / 0262	User code

9 Messages

In the case of an error, the directional pad starts flashing red and a message is indicated in the status display. A warning triangle is additionally indicated. If more than one error or fault condition has occurred, only the one with the highest priority will be displayed as a message in the status display.

In the case of a sensor error, the system is switched off, and a message appears on the display marked by an "E". Additionally, a corresponding value for the error type assumed is indicated.

Error message	Value	Cause	Solution
FS1 ... 7; FS6, 8	-88.8	Short circuit at sensor 1 ... 7	Check the cable.
	888.8	Broken cable at sensor 1 ... 7	
EVFS	9999	Error at Grundfos Direct Sensor™ VFS	Sensor fault. Check and, if necessary, correct the connection of the sensor plugs. If a sensor signal does not appear, the sensor has to be replaced.
ERPS	9999	Error at Grundfos Direct Sensor™ RPS	Check the system for a leakage.
ELEAK	Measured minimum pressure	Leakage error	Check the functioning of the valves and pumps.
EPRES	Measured maximum pressure	Pressure error	
EFLOW		Flow rate error	Check the pump.
		Threshold values for VFS 1-10: 1.0 - 1.1 l/min	Check whether a flow rate exists.
		Threshold values for VFS 2-40: 2.0 - 2.1 l/min	
PARAM		Remote parameterisation	Do not parameterise the controller via the push buttons during remote parameterisation.

After the error has been removed, the error message disappears.

10 Troubleshooting

If a malfunction occurs, a message will appear on the display of the controller.

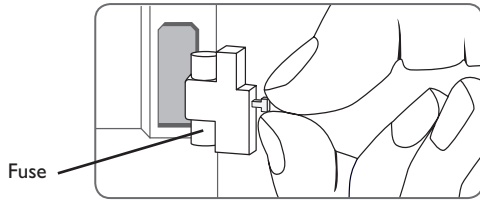

The display is permanently off.

Press button **S**. Display illuminated?

no

yes

Controller has been in standby, everything o.k.

Check the power supply of the controller. Is it disconnected?

no

yes

The fuse of the controller could be blown. The fuse holder (which holds the spare fuse) becomes accessible when the cover is removed. The fuse can then be replaced.

Check the supply line and reconnect it.

Directional pad flashes red. The symbol is indicated on the display and the symbol flashes.

Sensor fault. An error code instead of a temperature is shown on the corresponding sensor display channel.

888.8

- 88.8

Cable is broken.
Check the cable.

Short circuit.
Check the cable.

Disconnected temperature sensors can be checked with an ohmmeter. Please check if the resistance values correspond with the table.

°C	°F	Ω	°C	°F	Ω
-10	14	961	55	131	1213
-5	23	980	60	140	1232
0	32	1000	65	149	1252
5	41	1019	70	158	1271
10	50	1039	75	167	1290
15	59	1058	80	176	1309
20	68	1078	85	185	1328
25	77	1097	90	194	1347
30	86	1117	95	203	1366
35	95	1136	100	212	1385
40	104	1155	105	221	1404
45	113	1175	110	230	1423
50	122	1194	115	239	1442

Resistance values of Pt1000 sensors



Note:

For answers to frequently asked questions (FAQ) see www.resol.com.

Pump is overheated, but no heat transfer from the collector to the store, flow and return have the same temperature; perhaps also bubbling in the lines.

Air or gas bubbles in the system?

no

yes

Is the collector circuit blocked at the dirt trap?

yes

Vent the system; increase the system pressure to a static primary pressure of at least plus 0.5 bar; if necessary continue to increase pressure; switch the pump on and off for a short time.

Clean dirt trap

Pump starts up very late.

Switch-on temperature difference ΔT_{on} too large?

no

yes

Non-ideal position of the collector sensor (e. g. flatscrew sensor instead of sensor in immersion sleeves).

yes

Change ΔT_{on} and ΔT_{off} correspondingly.

Activate tube collector function if necessary.

o.k.

Pump starts for a short moment, switches off, switches on again, etc.

Temperature difference at the controller too small?

no

yes

Wrong position of collector sensors?

no

yes

Plausibility control of the option tube collector special function

Change ΔT_{on} and ΔT_{off} correspondingly.

no

o.k.

Mount the collector sensor at solar flow (warmest collector output); use immersion sleeve of the respective collector.

The temperature difference between store and collector increases enormously during operation; the collector circuit cannot dissipate the heat.

Collector circuit pump defective?

no

yes

Check/replace it

Heat exchanger calcified?

no

yes

Decalcify it

Heat exchanger blocked?

no

yes

Clean it

Heat exchanger too small?

yes

Replace with correctly sized one.

The solar circuit pump does not work, although the collector is considerably warmer than the store.

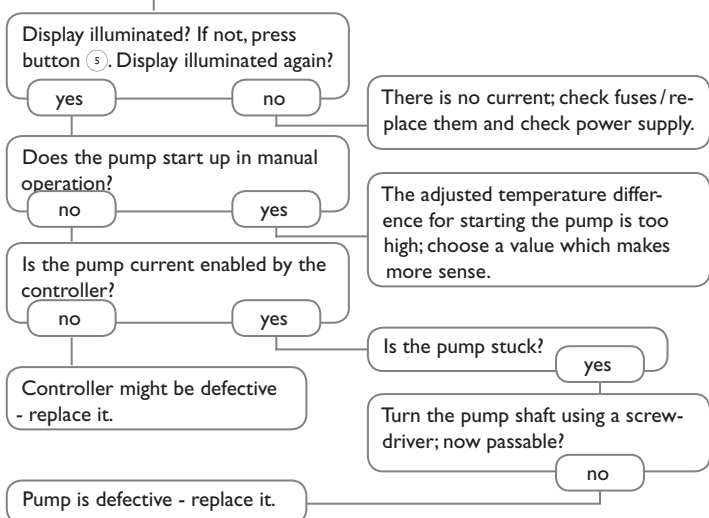

Stores cool down at night.

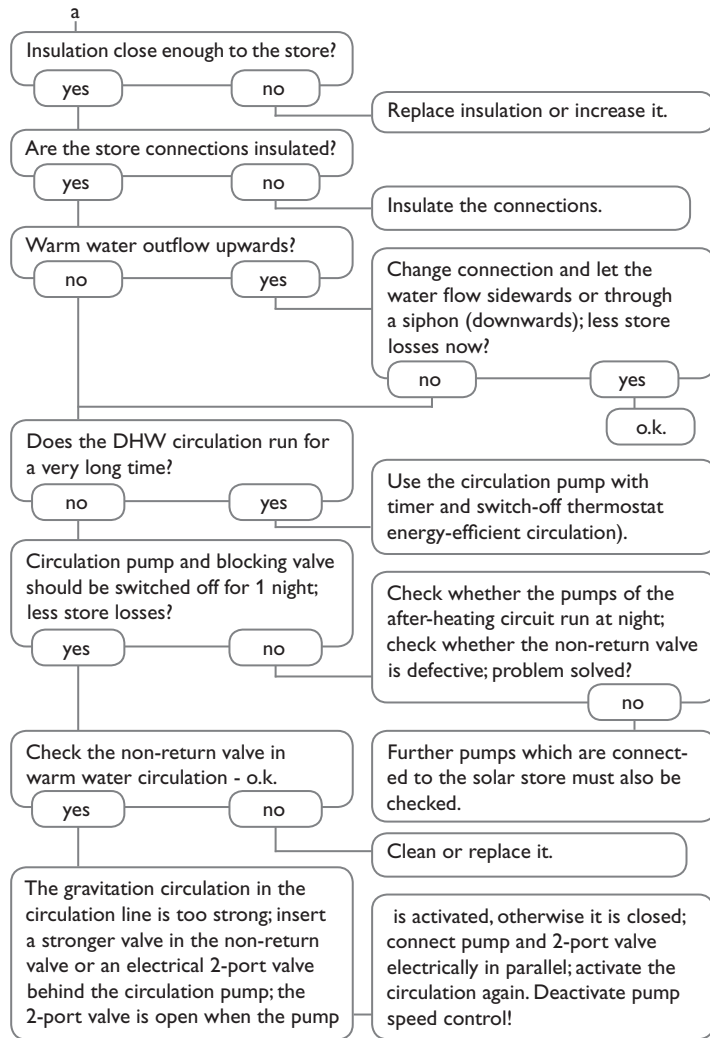
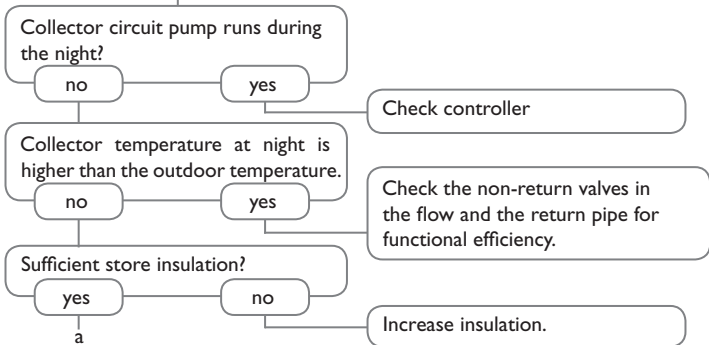



Sensors



Overvoltage protection device



VFS and RPS Grundfos Direct Sensors™



V40 flowmeter



RESOL VBus® / USB & VBus® / LAN interface adapters



SD3 Smart Display / GA3 Large Display



AM1 Alarm Module



DL2 Datalogger



KM2 Communication Module



11.1 Sensors and measuring instruments

Sensors

The product range includes high-precision platinum temperature sensors, flatscrew sensors, outdoor temperature sensors, indoor temperature sensors, cylindrical clip-on sensors, also as complete sensors with immersion sleeve.

Overvoltage protection device

In order to avoid overvoltage damage at collector sensors (e.g. caused by local lightning storms), we recommend installing the RESOL SP10 Overvoltage protection.

VFS and RPS Grundfos Direct Sensors™

The RPS Grundfos Direct Sensor™ is an analogue sensor that measures both temperature and pressure. The VFS Grundfos Direct Sensor™ is an analogue sensor that measures both temperature and flow rate.

V40 flowmeter

The RESOL V40 is a measuring instrument for detecting the flow of water or water/glycol mixtures. After a specific volume has passed, the V40 reed switch sends an impulse to the calorimeter. The heat quantity used is calculated by the calorimeter using these impulses and the measured temperature difference with the help of pre-defined parameters (glycol type, concentration, heat capacity, etc.).

11.2 VBus® accessories

SD3 Smart Display/GA3 Large Display

The RESOL SD3 Smart Display is designed for simple connection to RESOL controllers via the RESOL VBus®. It is used for visualising data issued by the controller: collector temperature, store temperature and energy yield of the solar thermal system. The use of high-efficiency LEDs and filter glass assures a high optical brilliance. An additional power supply is not required. One module is required per controller.

The GA3 is a completely mounted large display module for visualisation of collector- and store temperatures as well as the heat quantity yield of the solar system via one 6-digit and two 4-digit 7-segment displays. An easy connection to all controllers with a RESOL VBus® is possible. The front plate is made of antireflective filterglass and is printed with a light-resistant UV-lacquering. The universal RESOL VBus® allows the parallel connection of 8 large displays as well as additional VBus® modules.

AM1 Alarm module

The AM1 Alarm module is designed to signal system failures. It is to be connected to the VBus® of the controller and issues an optical signal via the red LED if a failure has occurred. The AM1 also has a relay output, which can e. g. be connected to a building management system (BMS). Thus, a collective error message can be issued in the case of a system failure.

DL2 Datalogger

This additional module enables the acquisition and storage of large amounts of data (such as measuring and balance values of the solar system) over a long period of time. The DL2 can be configured and read-out with a standard Internet browser via its integrated web interface. For transmission of the data stored in the internal memory of the DL2 to a PC, an SD card can be used.

The DL2 is appropriate for all controllers with RESOL VBus®. It can be connected directly to a PC or router for remote access and thus enables comfortable system monitoring for yield monitoring or for diagnostics of faults.

KM2 Communication module

The KM2 Communication module is the ideal interface between a solar or heating controller and the Internet. Due to the easy and secure connection to the VBus.net Internet portal, system data can be visualised and for example reports on system status via e-mail made available. With the RESOL RPT Parameterisation Tool the controller can be parameterised over the Internet.

VBus.net

The Internet portal for easy and secure access to your system data. VBus.net is all about the data of your RESOL controller. Live data of your system, customized filter settings and much more await you.

11.3 Interface adapters

RESOL VBus®/USB & VBus®/LAN interface adapters

The VBus®/USB interface adapter is the interface between the controller and a personal computer. With its standard mini-USB port it enables a fast transmission of system data for processing, visualising and archiving data via the VBus®. The RESOL ServiceCenter software is included.

The VBus®/LAN interface adapter is designed for the direct connection of the controller to a PC or router. It enables easy access to the controller via the local network of the owner. Controller access and data charting can be effected from every workstation of the network by means of the RESOL ServiceCenter Software. The VBus®/LAN interface adapter is suitable for all controllers equipped with a RESOL VBus®. The RESOL ServiceCenter software is included.

A		H	
Accessories.....	72	Heat dump.....	56
Antifreeze function.....	51	Heat exchange function.....	57
B		Heat quantity measurement.....	63
Backup heating.....	58	HE pump.....	35
Blocking protection.....	60	L	
Booster function.....	54	Language.....	66
C		Legionella protection (Thermal disinfection).....	60
Channel display.....	36	Loading logic.....	52
Code.....	68	Loading store.....	48
Collector cooling.....	49	M	
Collector emergency shutdown.....	49	Manual mode.....	60
Collector minimum temperature.....	50	Measurement values.....	38
Commissioning.....	39	Menu overview.....	45
Cooling functions.....	55	Menu structure.....	36
D		Messages.....	68
ΔT control.....	47	Monitoring-Display.....	36
Data communication / Bus.....	6	Mounting.....	5
Differential temperature control (ΔT control).....	47	O	
Drainback option.....	53	Overrun.....	54
E		P	
Electrical connection.....	5	Parallel relay.....	61
Error message.....	68	Pressure monitoring.....	64
F		Priority logic.....	51
Flow rate monitoring.....	64	PWM pump.....	59

R

Return preheating..... 57

S

SD card..... 66

Sensors 63

Solid fuel boiler..... 57

Speed control..... 47

Spreaded loading option..... 52

Store cooling..... 55

Successive loading option..... 52

System cooling..... 55

System overview 7

System selection..... 46

T

Thermal disinfection..... 60

Thermostat function 58

Time and date..... 65

Troubleshooting..... 69

Tube collector function..... 50

U

Unit..... 66

User code 68

Distributed by:

RESOL – Elektronische Regelungen GmbH

Heiskampstraße 10
45527 Hattingen / Germany

Tel.: +49 (0) 23 24 / 96 48 - 0

Fax: +49 (0) 23 24 / 96 48 - 755

www.resol.com

info@resol.com

Important note

The texts and drawings in this manual are correct to the best of our knowledge. As faults can never be excluded, please note:

Your own calculations and plans, under consideration of the current standards and directions should only be basis for your projects. We do not offer a guarantee for the completeness of the drawings and texts of this manual - they only represent some examples. They can only be used at your own risk. No liability is assumed for incorrect, incomplete or false information and / or the resulting damages.

Note

The design and the specifications can be changed without notice.
The illustrations may differ from the original product.

Imprint

This mounting- and operation manual including all parts is copyrighted. Another use outside the copyright requires the approval of RESOL – Elektronische Regelungen GmbH. This especially applies for copies, translations, micro films and the storage into electronic systems.

© RESOL – Elektronische Regelungen GmbH